



**MR300i**



**OWNER'S MANUAL**



## TABLE OF CONTENTS

Important Notices .....	4	Piston and piston ring .....	50
Vehicle registration .....	9	Cylinder head, cylinder, and exhaust valve .....	50
Vehicle delivery (complete upon first delivery) .....	10	Exhaust system .....	51
Inspection prior to delivery (Adjustments) .....	11	Silencer packing .....	52
Technical info .....	14	Connecting rod and bearings .....	53
Tightening .....	20	Kickstart pedal and gearshift pedal .....	53
Approval .....	24	Exhaust/silencer rubber joint .....	53
Location of serial numbers .....	25	Engine bearings .....	53
Main vehicle elements .....	26	Coolant fluid .....	54
Information on use .....	29	Radiator hose and connections .....	58
Break-in phase .....	29	Brake adjustment .....	59
Daily inspection before riding .....	30	Brake wear .....	61
<b>Inspection and Maintenance .....</b>	<b>38</b>	Brake fluid .....	66
Daily inspection .....	38	Brake fluid level .....	66
Maintenance Schedule .....	39	Brake master cylinder piston and dust seal (front and rear) .....	67
Clutch .....	42	Brake calliper piston and dust seal (all callipers) .....	67
Clutch discs .....	42	Brake hoses .....	67
Throttle .....	43	Spokes and rims .....	67
Spark plug .....	44	Chain guide .....	69
Air filter .....	45	Chain guide wear .....	69
Cleaning the air filter .....	47	Chain guide slider .....	69
Transmission oil .....	49		



Front suspension .....	70	Warranty .....	111
Front suspension oil.....	72		
Fuel system.....	73		
Steering play.....	73		
General lubrication .....	75		
Steering bearing .....	77		
Wheel bearing .....	77		
Swingarm and linkages .....	77		
Rear suspension .....	78		
Chain .....	82		
Tyres .....	85		
Battery charge .....	86		
<b>Adjustments.....</b>	<b>88</b>		
Introduction.....	88		
Secondary drive .....	88		
Front suspension .....	89		
Front suspension adjustments.....	91		
Rear shock absorber .....	92		
<b>Troubleshooting.....</b>	<b>97</b>		
<b>Vehicle storage and cleaning .....</b>	<b>105</b>		
<b>Modifications and accessories.....</b>	<b>110</b>		



## IMPORTANT NOTICES

These are the safety alert symbols. Always follow all safety messages that accompany these symbols to avoid possible injury or death.



### **WARNING:**

Indicates that failure to follow the procedure described in this Owner's and Maintenance Manual could result in serious injury or death.



### **CAUTION:**

Indicates that failure to follow the instructions in this manual may result in personal injury or damage to the vehicle.



### **TIP:**

Additional information provided by Rieju.



**RIEJU S.A.** would like to thank you for your trust in our company and congratulate you on an excellent choice.

The **MR300i** model is the result of **RIEJU'S**, extensive experience in developing high-performance vehicles.

The purpose of this Owner's Manual is to set forth how to use and maintain your vehicle. We ask that you carefully read the instructions and information provided as follows.

Please remember that the vehicle's life cycle depends on how you use and maintain it. Keeping it in perfect operating condition reduces the cost of repairs.

Please consider this manual an integral part of the vehicle. It must remain with its basic equipment, even in the event of a change in ownership.

For any issues, please see your **RIEJU** dealer, who will be delighted to serve you, or visit:

**[www.riejumoto.es](http://www.riejumoto.es)**

Remember that for your vehicle to operate properly, you **MUST** always request original replacements.



This use and maintenance manual is a permanent document for the motorcycle. Even if the motorcycle is transferred to another person, this manual must also be transferred to the new owner.

Copying or re-printing any part of this manual is strictly prohibited without the company's written authorisation.



**CAUTION:**

- Driver and passenger
- This motorcycle is designed to be used solely by one driver and one passenger.



**CAUTION:**

- Road conditions for driving.
- This motorcycle is suitable for road driving.



**CAUTION:**

- Carefully read this use and maintenance manual. Proper break-in will ensure optimal performance and stable handling.

**CAUTION:**

- Three of every four lethal accidents are due to head injury. The risk of suffering brain injury increases three-fold when you do not use a helmet. Always wear an approved helmet. The likelihood of emerging from an accident unscathed increases by 20%. We also recommend wearing eye protection and gloves, boots, and other protective elements in perfect condition.
- Never carry passengers. Your **RIEJU** is not approved to this end. There is no space on the saddle, no grips, and no footrests for passengers. Additionally, the extra weight can jeopardise handling.
- Do not modify your **RIEJU** with non-original accessories and do not remove original elements. These changes can affect stability and handling, making the vehicle dangerous or illegal. We recommend using original spare parts and accessories approved by **RIEJU**. This condition is essential for the warranty to remain valid.
- Your **RIEJU** was designed for off-road use. It was not designed for long trips on roads or motorways. This sort of use could lead to engine damage, due to high revolutions maintained over time, and because the tyres are not suitable for use on paved surfaces. It was not designed for city use, either. Long stops at traffic lights in the city could cause the engine to overheat.
- Keep your **RIEJU** in good condition. To avoid all problems, inspect your motorcycle before each use and conduct all maintenance as recommended in this manual. After a fall, verify that the main elements have suffered no damage. Driving a motorcycle in poor condition can lead to an accident, with serious injury or even death.



**CAUTION:**

- The exhaust pipe and other elements reach high temperatures during use and may take some time to cool after turning off the engine. Avoid handling or touching elements during this period. We do not recommend wearing shorts; this can lead to burns on the legs.



**CAUTION:**

- Avoid wearing loose clothing that can snag on parts of the vehicle or the surrounding environment. Although total safety is impossible, using adequate gear reduces the likelihood and/or severity of injury.



## VEHICLE REGISTRATION

Please make a note of the chassis and engine serial numbers, which will help you for all purposes (certificate of characteristics, insurance, registration, etc.).

These numbers will be useful for you for any suggestions or complaints, as well as to order replacement parts.

Chassis serial number (p.25)

Engine serial number (p.25)

Dealer seal



## **VEHICLE DELIVERY (complete upon first delivery)**

- USER MANUAL**  
Explain the importance of reading it and understanding all the information. Highlight the sections on safety and maintenance practises.
- WARRANTY REGISTRATION CARD**  
Fill out all necessary information and provide a copy to the client.
- HANDLING**  
Explain how to properly handle the vehicle.
- WARNINGS**  
Explain the importance of the warnings to guarantee a long “life” for the vehicle.
- KEYS**  
Deliver the complete set. Advise them to make a backup copy of the set.
- FIRST INSPECTION**  
Explain that an inspection after 500 km is important.
- PERIODICAL MAINTENANCE**  
Explain the need for periodical maintenance and state that failure to comply with guidelines for check-up and visiting the shop is grounds for “Loss of Vehicle Warranty.”



**INSPECTION PRIOR TO DELIVERY (Adjustments)**

- General appearance** .....  .....
- Engine**
- Engine oil level .....  .....
- Chassis**
- No fuel leaks in: Tank output, fuel tap, and supply lines .....  .....
- Front and rear brake - Drain, if necessary .....  .....
- Coolant level .....  .....
- Front, rear mudguard and attachment elements .....  .....
- Wiring of electrical installation around the steering column .....  .....
- Alignment of front, rear wheels, and tightening torque of wheel axles .....  .....
- Front and rear wheel spokes .....  .....
- Tyre pressure .....  .....
- Chain tension .....  .....
- Checking the equipment**
- Accelerator works and has free play. Adjust if necessary .....  .....
- Degrease both brake discs .....  .....
- Battery charged and terminals greased .....  .....
- Block steering or anti-theft block .....  .....
- Electric start-up engine operation .....  .....



- General condition of front and rear suspension .....  .....
- Clutch cable properly adjusted .....  .....
- Operation of fuel cap closure .....  .....
- General inspection of nuts and screws: Callipers/discs, transmission/pinions, wheel nuts, tilt, engine mounts, exhaust system, shock absorber, gear selector, brake pedal/levers, manifold nuts, etc. ....  .....

**Fuel tank**

- Check that the tank is not in contact with the frame .....  .....

**Driving components**

- The digital instrument dashboard checks itself when the ignition is turned on .....  .....
- Adjusting the headlight height .....  .....
- Brake light when pressing brake levers LH and RH .....  .....
- Front, rear blinkers and mounting clips .....  .....
- Horn operation .....  .....

**ON-ROAD TEST, at least 10 km**

- Engine and gearbox operation .....  .....
- Grip on road and suspensions .....  .....
- No abnormal sounds .....  .....



**AFTER ON-ROAD TEST**

- Coolant leaks .....  .....
- Fuel system, including hoses, clips, and all associated parts where leaks may appear .....
- Brake light operation when the left and right brake levers are applied .....  .....

**CHECKING FINAL APPEARANCE** .....

Date

Manufacturer signature



## TECHNICAL INFO

FRAME		
Type		Steel central spine frame (25CrMo4), aluminium alloy subframe
Tyre and wheel measurements	Front	Excel 1.6 x 21 - 90/90 - 21 M/C 54R MICHELIN ENDURO MEDIUM F TT
	Rear	Excel 2.15 x 18 - 140/80 - 70R MICHELIN ENDURO MEDIUM R TT
Tyre pressure	Front	1.0 bar
	Rear	1.0 bar
Suspension	Front	KYB 48 mm AOS (Air-Oil Separated) front fork, closed-cartridge, with adjustable spring, compression, and rebound.
	Rear	Progressive system with KYB monoshock, adjustable for high- and low-speed compression and rebound
Suspension travel	Front	300mm (KYB)
	Rear	131 mm (KYB)
Front fork oil volume		350 ml. (KYB)
Brakes	Front	Disc brake, with a floating 2-piston Nissin caliper
	Rear	Disc brake, with a floating 1-piston Nissin caliper
Brake discs	Front	NG "wave" disc, Ø260 mm
	Rear	NG "wave" disc, Ø220 mm



<b>DIMENSIONS</b>	
Total height	1235 mm
Total length	2145 mm
Saddle height	960 mm
Ground clearance	375 mm
Total width	810 mm
Distance between axles	1480 mm
Dry weight	105 kg
Petrol tank capacity	10 l



<b>ENGINE</b>	
Cycle	2-stroke
Number of cylinders	Single cylinder
Cooling	Liquid
Displacement	299.3 cc
Diameter	72.0 mm
Stroke	72.0 mm
Carburetor	Dell'Orto PHBG 21 (Keihin PWKS 38 competition model)
Intake type	V-Force 4 reed valve
Lubrication system	Fuel-oil mixture
Starting system	Kick start/ Electric start on E-START models
Ignition system	Digital CDI-Euro 5
Ignition timing	
Spark plug	DENSO W24ESR-U y NGK BR8EG
Electrode gap	0.7/ 0.8 mm



TRANSMISSION		
Primary reduction	3,31 (63/19)	
Gearbox	6 velocidades en cascada	
Gear ratios	1st	2.07 (14/29)
	2nd	1.63 (16/26)
	3rd	1.33 (18/24)
	4th	1.10 (20/22)
	5th	0.91 (23/21)
	5th	0.79 (24/19)
Secondary transmission	Chain drive	
Secondary reduction	3.69 (13/48) chain models only	
Chain	110 links // 5/8" x 1/4" with O-rings (112 links) competition models only	
Clutch type	Multi-plate wet clutch with hydraulic operation	
Clutch actuation	Hydraulic	
Lubrication	Oil bath	Oil
	Capacity	900cc (new) ; 800cc (replacement)



FLUIDS	RECOMMENDED	
Fuel		Unleaded (minimum RON 98)
Recommended fuel	(E5) (E10)	Fuel with up to 10% ethanol content
Premix oil (JASO FC)	GRO 2T SYNT 10 OFFROAD RACE	100% synthetic oil at 2% (50:1) Semi-synthetic oil at 2% (50:1) Mineral oil at 3% (32:1)
Coolant fluid*	GRO	100% antifreeze
Brake fluid	GRO DOT-4	DOT-4
Clutch master cylinder fluid	GRO ULTRA 5	Hydraulic mineral oil
Transmission oil	GRO RACING 10W50 FULL SYNTHETIC	Full Synthetic high Performance oil JASO MA2-API SN
Fork oil	KYB	KYB Fork oil 01M

\*In cold countries, adjust antifreeze to ambient temperature



# REV. 3.2 (19/05/2025) MOTOR ARRANQUE DIRECTO

REV. 3.2 (19/05/2025) MOTOR ARRANQUE DIRECTO

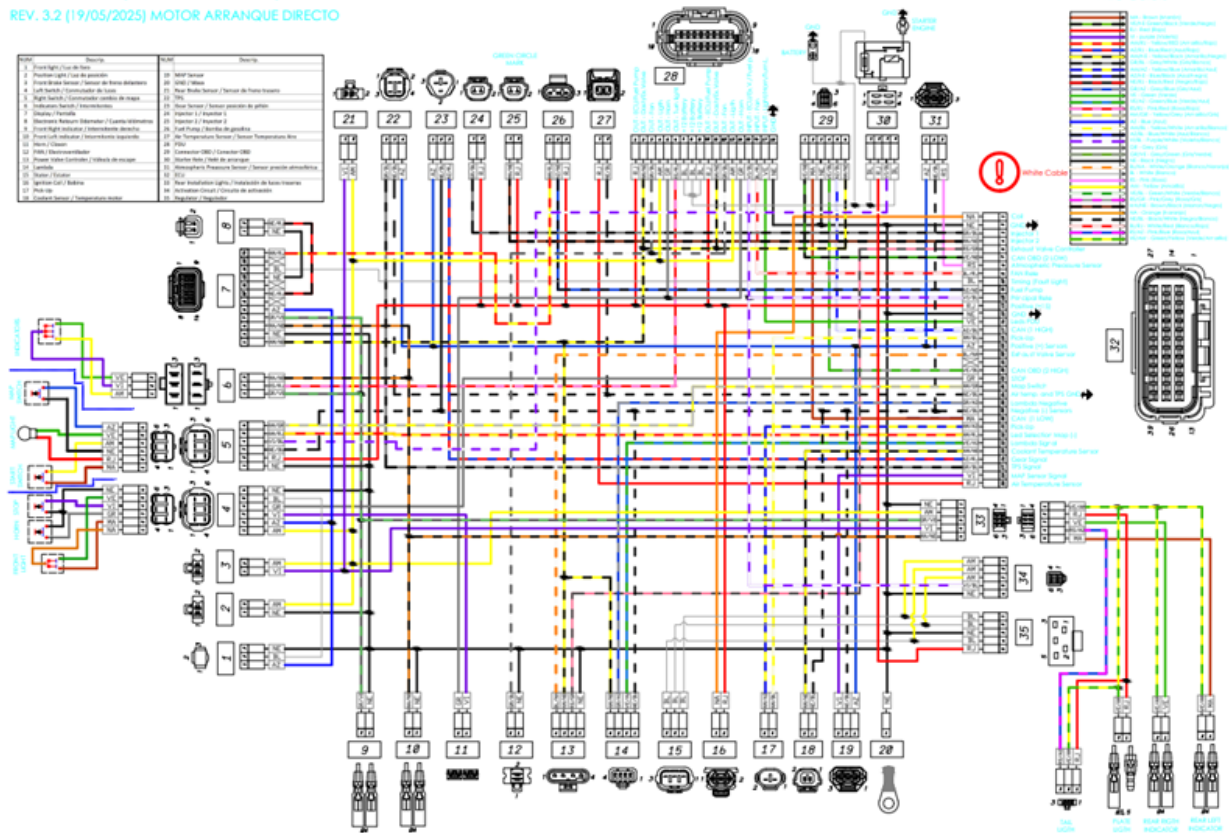



## TIGHTENING

Part	Engine	Size	Torque (Nm)	Remarks
Nut	Engine shafts	M10	60	

Part	Handlebar	Size	Torque (Nm)	Remarks
Screw	Lower handlebar clamp	M10	50	
Screw	Upper handlebar clamp	M8	25	
Screw	Clutch	M6	10	

Part	Frame	Size	Torque (Nm)	Remarks
Screw	Crankcase guard	M6	10	
Screw	Left side guard	M6	10	
Screw	Cylinder head rod	M8	25	

Part	Subframe	Size	Torque (Nm)	Remarks
Screw	Upper subframe	M8	25	Loctite® 243™
Screw	Lower subframe	M8	25	Loctite® 243™



Part	Fork	Size	Torque (Nm)	Remarks
Screw	Fork guard - Hose guide	M6 (pl)	8	
Screw	Fork guard - Foot	M6	8	
Screw	Fork foot	M8	15	
Screw	Front axle	M24	35	
Screw	Front axle	M8	25	Loctite® 243™
Screw	Upper clamp	M7	15	
Screw	Lower clamp	M7	12	

Part	Tank	Size	Torque (Nm)	Remarks
Screw	Tank-Silentblock-frame	M6	10	

Part	Tank-Silentblock-frame	Size	Torque (Nm)	Remarks
Screw	Upper shock absorber	M12	60	Loctite® 243™
Screw	Lower shock absorber	M12	50	

Part	Link	Size	Torque (Nm)	Remarks
Nut	Linkage - frame	M12	80	Loctite® 243™
Nut	Linkage - frame	M12	80	Loctite® 243™
Nut	Rocker arm - swingarm	M12	80	Loctite® 243™



Part	Swingarm	Size	Torque (Nm)	Remarks
Nut	Swingarm nut	M14	80	
Screw	Chain slider - protector	M6	10	
Screw	Chain slider - protector	M8	25	Loctite® 243™
Screw	Chain guide	M6	10	
Nut	Rear wheel axle nut	M20	100	

Part	Exhaust	Size	Torque (Nm)	Remarks
Screw	Silencer - Upper	M6	12	Loctite® 243™
Screw	Silencer - lower	M6	12	Loctite® 243™
Screw	Silentblock exhaust	M6	12	Loctite® 243™

Part	Plastic	Size	Torque (Nm)	Remarks
Screw	Silentblock exhaust	M6	12	
Screw	Silentblock exhaust	M6	12	
Screw	Lower side panels to radiator	M6	8	
Screw	Tank and panels	M6 (pl)	6	
Screw	Tank and panels	M6	12	
Screw	Tank and panels	M6 (pl)	6	
Screw	Tank and panels	M8	25	Loctite® 243™



Part	Rear brake	Size	Torque (Nm)	Remarks
Screw	Brake pedal	M8	20	
Screw	Rear brake pump	M6	12	Loctite® 243™
Part	Electricity	Size	Torque (Nm)	Remarks
Screw	Battery	M5	2,5	
Part	Battery	Size	Torque (Nm)	Remarks
Screw	Gearshift pedal	M6	12	
Part	Kickstart pedal	Size	Torque (Nm)	Remarks
Screw	Kickstart pedal	M6	12	Loctite® 243™
Part	Saddle	Size	Torque (Nm)	Remarks
Screw	Saddle	M6	10	



## APPROVAL

The vehicle you have just purchased is an approved vehicle under EU directives and meets all required approval standards.

Mandatory approval components to ride on public streets and to pass technical inspections at ITV (Technical Vehicle Inspection) stations include, but are not limited to, the following.

In addition to other requirements, approval components are identified with a certain mark and are registered.

Each of the approval components must form part of the vehicle. In the event of breakage, loss, or improper function, we recommend that the owner go to their official **RIEJU** dealer to correct the issue.

List of components	Qty./motorcycle
Manufacturer identification plate	1
Catalytic exhaust	1
Approved rear sprocket and pinion	1
Fuel overflow assembly	1
Front and rear blinkers	4
Approved number plate holder + Light + Reflector	1 / 1 / 1
Front reflectors	2
Speedometer	1
Horn	1
Rear-view mirror	2
Anti-theft steering block	1
Secondary air valve	1
Air filter restriction	1
Throttle stop limiter	1
Approved throttle and choke cable	1 / 1
Blow-by tube assembly	1



## LOCATION OF SERIAL NUMBERS

### Frame identification number (1)

Your **RIEJU** has an identification plate (1) with details on: manufacturer, frame number, approval number, and sound emissions level.

The frame number is also die-cut on the right side of the steering tube.

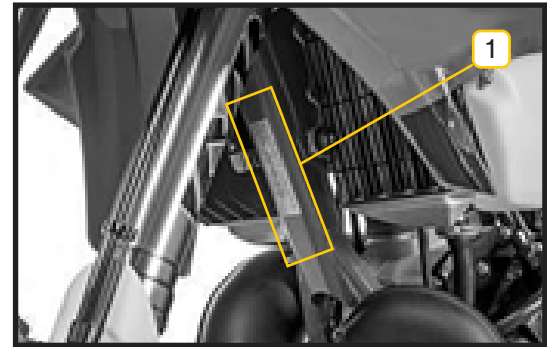

### Lock system

Your **RIEJU** has an anti-theft steering block system. It is to the right of the fork's lower clamp. To block steering:

1. Turn the handlebar totally to the left.
2. Insert the key into the anti-theft and turn it anti-clockwise.
3. Push the key inward.
4. Turn the key clockwise, back to its initial position, and remove it. The lock is depressed when the block is successful.





## MAIN VEHICLE ELEMENTS

1. Front reflectors
2. Position, low and high beam headlight
3. Front blinkers
4. Rear-view mirrors
5. Overflow
6. Fuel tank
7. Fuel line connector
8. Air filter
9. Side stand
- 10.Chain guard
- 11.Number plate
- 12.Front brake disc
- 13.Front brake caliper
- 14.Front fork
- 15.Starter motor
- 16.Gearshift pedal
- 17.Secondary air exhaust
- 18.Throttle body
- 19.Chain
- 20.Chain guide

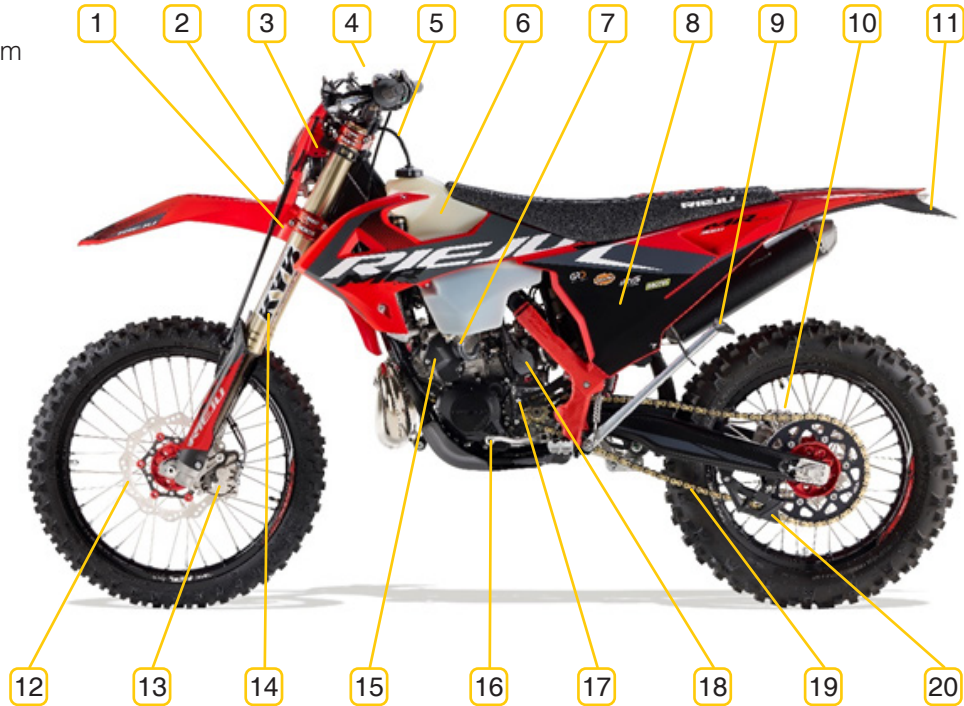



- 21. Silencer
- 22. Rear brake fluid tank
- 23. Saddle
- 24. Rear shock absorber gas tank
- 25. Throttle body
- 26. Frame VIN number
- 27. Radiator
- 28. Rear brake disc
- 29. Rear brake caliper
- 30. Linkage and rocker arm suspension system
- 31. Footpegs
- 32. Rear brake pedal
- 33. Water pump
- 34. Crankcase guard
- 35. Exhaust
- 36. Manufacturer identification plate



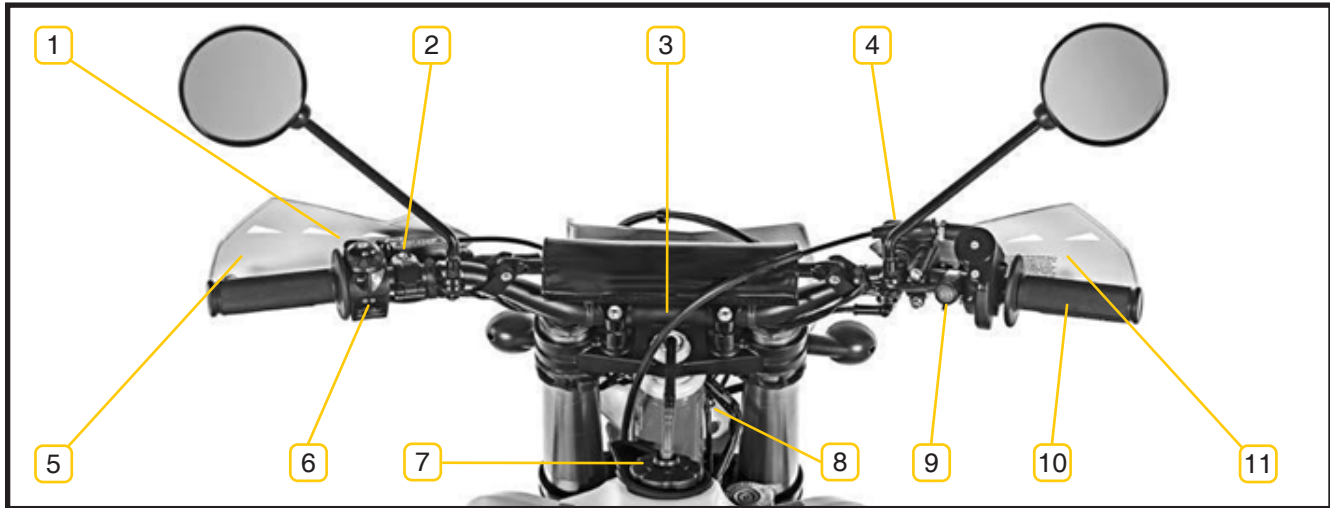

1. Choke lever
2. Clutch fluid tank.
3. Multifunction indicator.
4. Front brake fluid tank.
5. Clutch lever.
6. Handlebar controls: lights, horn, stop.

7. Fuel tank cap.
8. Anti-theft steering block.
9. Change map button, start-up button.
10. Throttle grip.
11. Front brake lever.



## INFORMATION ON USE

### Break-in phase

It is IMPORTANT to respect the break-in period. This ensures the long-term durability and proper operation of your engine. Please observe the following intervals:

1. From 0 to 200 km: Ride at 50% to 75% throttle, alternately, without continuously using 75% throttle.
2. From 200 to 300 km: Ride the same, but occasionally reach 100% throttle without holding for more than 5-10 seconds.
3. From 300 to 400 km: Ride from 75% to 100% throttle, alternately, without holding full throttle.
4. From 400 km up, increase load gradually over 60-80 km until reaching full performance.



### CAUTION:

- Reckless acceleration may cause problems with the engine. Use caution and skills and techniques necessary for safe motorcycle riding.



## Daily inspection before riding

Before each use of your motorcycle, you must perform the following inspections:

**Is there enough fuel?** Open the fuel cap. When you move the motorcycle from side to side with the handlebar, you will see and hear the fuel, which gives you an approximate idea of content.

**Is the engine oil at the correct level?** Through the oil viewer (2), check that the level is correct. If necessary, add more.

**Is the coolant at the correct level?** When you remove the radiator filler cap, you can check the coolant level. It should be just below the metal edge (3). If necessary, add more.



### CAUTION:

- Do not open the cap when the engine is hot. There is a risk of serious burns.



### Are the brake fluid tanks at the correct level?

The brake fluid tanks, one for each brake, have a viewer (1 and 2) so you can check their level.



#### CAUTION:

- If the brake fluid level is nearing half in the viewer, both the front and the back brake, check brake pad thickness and check that they have not reached their limit for use. If the thickness is correct, refill the brake fluid and check that there are no leaks. If you are unsure, contact your official Rieju dealer immediately. They know what must be done in each case. This may affect your safety.

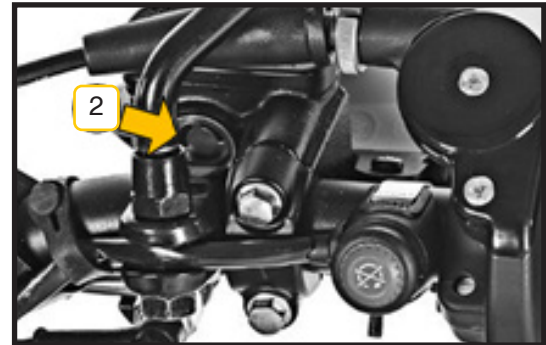
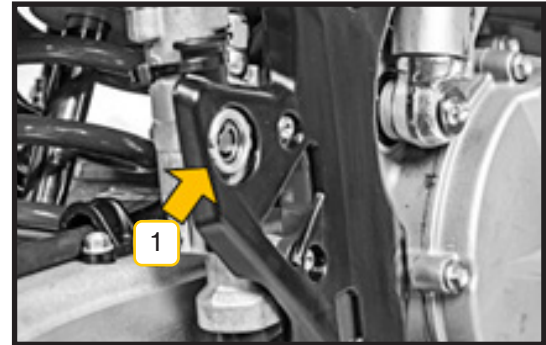



### Is the clutch fluid at the correct level?

Verify as follows: put the motorcycle on its stand with the handlebars turned fully toward the right. In this position, remove the tank cap along with its rubber boot (be careful of DIRT; you need a clean area to place the parts you have removed). Gently turn the handlebar to the left until the fluid level is parallel to the upper edge of the tank. The average level should not differ by more than 6-8 mm from the upper edge of the tank. If the level is lower than this, fill up. If you have any questions or detect anomalies, contact your official RIEJU service.

### Are the brake discs in good condition?

Visually check for large scratches, cracks, excess wear, etc.



#### CAUTION:

- Verify that the disc thickness is 3mm on the front and 3.5 mm on the rear at least. Immediately contact your official RIEJU service if you are unsure what to do in each case. This may affect your safety. You must not ride the motorcycle otherwise.





### Are the front and rear brake pads in good condition?

You can visually see the thickness of the remaining lining (1) to determine whether they are functioning correctly or must be quickly replaced. The lining thickness must be no less than 1 mm.

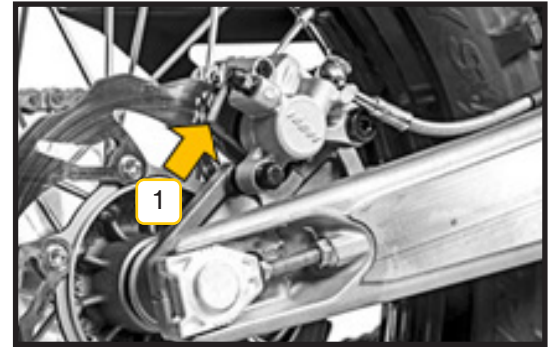

### Do the controls feel correct?

Front brake lever, rear brake pedal, clutch lever, gearshift pedal, choke lever, light switch, stop, horn and blinkers, throttle, kickstart pedal. All these controls and control elements have their characteristic feel and function. Any change indicates anomaly or wear. You know your motorcycle best. If you notice any change, you must immediately contact your official RIEJU service. The official RIEJU service will be delighted to serve you and ensure your safety.



### **Does the stand feel correct?**

The stand is a part of the motorcycle that tends to cause issues, even with safety, because it receives rough treatment. If you notice an unusual feel or it is difficult to fold it, first clean the entire assembly and check the fastening torque and the condition of the springs. If the abnormal behaviour continues, please immediately contact your official RIEJU service for your safety.



### **Does tyre pressure appear correct?**

If in doubt, ALWAYS check the pressure level. If the problem persists or repeats itself, this may be due to leaks. Please see your official RIEJU dealer.





### **Are the wheel spokes properly tensioned?**

Squeeze them with your fingers to detect possible lack of tension. If any spoke is too loose, you must check all of them and on both wheels. This is expert work; we recommend seeing your official RIEJU service.



### **Is the chain properly tensed and in proper condition?**

If necessary, adjust chain tension. If this need occurs too frequently or if you observe symptoms of wear on the sprocket, rear sprocket, slider, guides, or guard, please contact your official RIEJU service. This affects your safety.

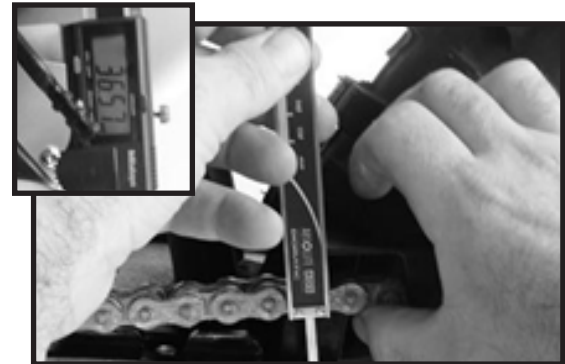



### **Is the saddle properly fixed?**

This point is vital for your safety. If there is any doubt regarding its attachment, please contact your official RIEJU service.

### **Are any elements at risk of detachment?**

Fenders, side panels, tank, dust covers, etc. If so, attempt to secure them or remove them completely to prevent possible falling for your safety. Please contact your official RIEJU dealer for repairs.

### **Does the front suspension need bleeding?**

(1) If your model requires bleeding, you must do so properly. Otherwise, this can pose a problem for your safety and reduce the lifespan of the front suspension.

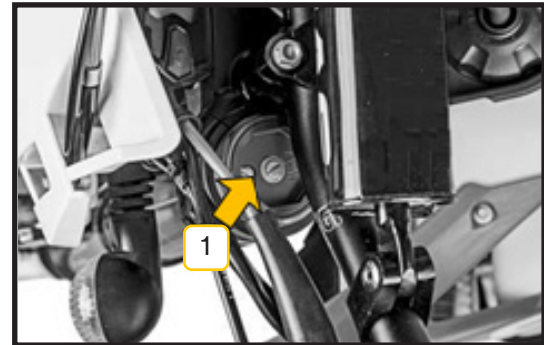



### Are there any leaks?

Visually inspect for any possible leaks, assess them based on their location, severity, and the type of product leaked (caution: fire hazard). Always contact your official RIEJU dealer as quickly as possible.



#### **CAUTION:**

- These inspections are very rapid; it is a matter of habit. The user knows how they used the motorcycle the last time and where to focus on during this inspection. Conducting these inspections means greater safety for the user, and certainly better and more economical maintenance of the motorcycle.



## INSPECTION AND MAINTENANCE

### Daily inspection

After using the vehicle under adverse conditions, after rain, or after washing the vehicle, you must properly lubricate it. To ride safely, you must maintain good lubrication of moving parts, which is necessary to prolong the service life of the vehicle.

Daily inspection and lubrication points include:

- Clutch lever.
- Brake lever.
- Brake pedal bearing.
- Side stand shaft and side stand spring hook.
- Main and passenger footrest shafts and return springs.
- Transmission chain.



## Maintenance Schedule

COMPONENT	Check / Inspect	Adjust	Check / Inspect	Clean	Check / Inspect
Clutch	10 hours	20 hours	when necessary	-	10 hours
Clutch discs	30 hours	when necessary	when necessary	-	-
Fuel line	10 hours	10 hours	-	-	10 hours
Spark plug	-	-	20 hours	10 hours	-
Air filter	0.5 hours	-	when damaged	when necessary	-
Carburetor	20 hours	when necessary	-	-	-
Transmission oil	-	-	20 hours	-	-
Piston and piston ring	20 hours	-	50 hours	-	-
Cylinder head, cylinder, and exhaust	-	-	when necessary	20 hours	-
Exhaust system	-	-	when necessary	-	-
Silencer packing	-	20 hours	30 hours	-	-
Connecting rod and bearings	80 hours	-	120 hours	-	-
Kickstart pedal and gearshift pedal	-	-	-	-	10 hours
Exhaust/silencer rubber joint	10 hours	-	when necessary	-	-
Crankshaft bearings	80 hours	-	120 hours or when necessary	-	-
Coolant fluid	-	-	30 hours	-	-
Radiator hose and connections	10 hours	-	40 hours	-	-
Brake adjustment	20 hours	-	when necessary	-	-

\* If the vehicle is used for competition, maintenance intervals are shorter.



COMPONENT	Check / Inspect	Adjust	Check / Inspect	Clean	Check / Inspect
Brake adjustment	30 hours	-	when necessary	-	-
Brake fluid	-	-	Every 2 years	-	-
Brake fluid level	10 hours	20 hours	when necessary		
Brake master cylinder piston and dust seal	-	-	Every 2 years	-	-
Brake piston and dust seal	-	-	Every 2 years	-	-
Brake hose	-	-	Every 4 years	-	-
Front spokes and rim	-	10 hours	When necessary, use Loctite 243 for spokes	-	-
Rear spokes and rim	-	10 hours	When necessary, use Loctite 243 for spokes	-	-
Chain guide	-	-	-	-	20 hours
Chain guide wear	20 hours	-	-	-	-
Chain guide slider	20 hours	-	when necessary	-	-
Front suspension	10 hours	when necessary	when necessary	when necessary	-
Front suspension oil	-	-	30 hours	-	-

\* If the vehicle is used for competition, maintenance intervals are shorter.



COMPONENT	Check / Inspect	Adjust	Check / Inspect	Clean	Check / Inspect
Bolts, nuts, and fasteners	10 hours	20 hours	when necessary	-	-
Fuel line	20 hours	-	when necessary	-	-
Fuel system	-	-	-	when necessary	-
Steering set	10 hours	-	-	-	-
General lubrication	-	-	-	-	20 hours
Steering bearing	-	-	-	-	30 hours
Wheel bearing	30 hours	-	when necessary	-	-
Swingarm and linkages	20 hours	-	when necessary	-	20 hours
Rear suspension	Every 2 years	when necessary	when necessary	-	-
Chain	-	10 hours	when necessary	-	-
Tyres	5 hours	-	when necessary	-	-
Battery charge	12 hours slow charge	-	-	-	-

\* If the vehicle is used for competition, maintenance intervals are shorter.



## Clutch

You can adjust the clutch lever for your comfort.

Proceed as follows to adjust:

- With the wheel (1), adjust the distance of the lever from the handlebar based on the rider's comfort.

The set is designed so that the lever position does not shift during operation.



### CAUTION:

- This model uses GRO ULTRA 5 FOR CLUTCH COMMAND mineral oil for the clutch's hydraulic circuit.

## Clutch discs

For this inspection, adjustment, or replacement, please contact your official RIEJU service.



## Throttle

- Check that the throttle control (1) rotates smoothly.
- Check that the control has 2-3 mm free play.
- If the free play is incorrect, loosen the locknut (2) at the end of the throttle cable. Turn the adjuster (2) for optimal free play.
- Tighten the locknut again.
- If you cannot set free play by adjusting the cable, remove the cable cover at the throttle body, adjust it with the adjuster at the end of the cable, tighten the locknut, and reinstall the cover.

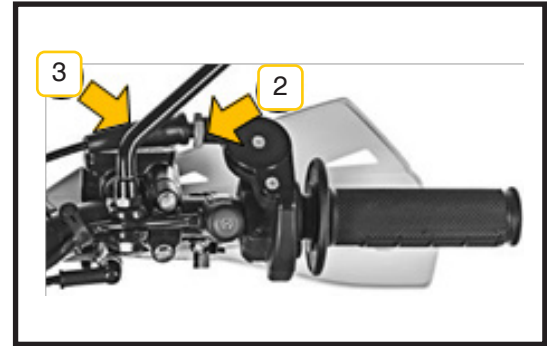



## Spark plug

The spark plug must be periodically removed to check the distance between electrodes (0.7-0.8 mm). If the spark plug contains oil or carbon deposits, clean with a wire brush or similar. Measure the distance between electrodes with a feeler gauge and adjust if incorrect by bending the outer electrode. If the spark plug electrodes are rusted, damaged, or the insulation is broken, replace the spark plug.



### CAUTION:

- Inspect every 10 hours and replace every 20 hours.
- To find the correct operating temperature of the spark plug, remove it and examine the ceramic insulator around the electrode. If the ceramic is light brown in colour, the spark plug's temperature matches the engine. If the ceramic is white, the spark plug must be replaced by a different cooler one. If it is black, it must be replaced by a hotter one.
- If the engine's performance decreases, replace the spark plug to restore normal performance.

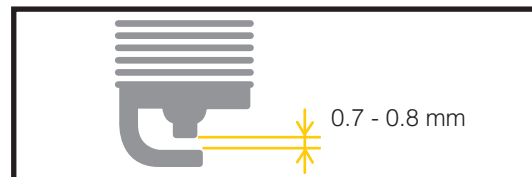

### SPARK PLUG TYPE

DENSO W24ESR-U or NGK BR8EG

### SEPARATION BETWEEN ELECTRODES

0.7 - 0.8 mm

### TORQUE

25 Nm



## Air filter

1. You must remove the left side cover to access the air filter.



2. Remove the filter pull tab.





3. Remove the air filter.

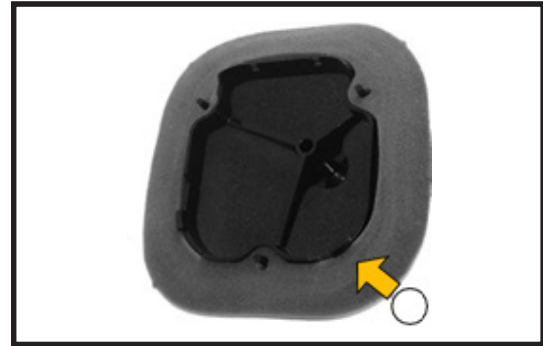



## Cleaning the air filter

1. Clean inside the filter box with a damp rag (1).
2. Remove the cage (2) from the air filter (3).
3. Clean the filter in a liquid filter-cleaning bath with a soft brush.
4. Squeeze and dry with a clean rag. Do not twist or blow it, as it may become damaged.
5. Install the filter in the cage and cover the filter lip (4) with a thick layer of grease to ensure proper sealing and to prevent dirt from entering.



### CAUTION:

- A clogged air filter allows dirt to enter the engine, causing excessive wear and damage.
- It is essential to inspect it before and after each ride or session. Clean if necessary. Clean the filter in a well-ventilated area and ensure that there are no sparks or flames near the work area (including a powerful light source). Do not use petrol to clean the filter, as this may cause an explosion.

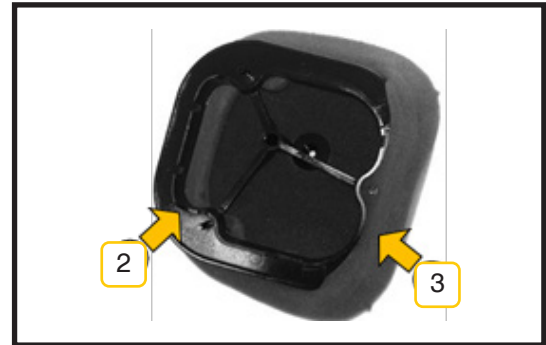



**CAUTION:**

- A clogged air filter allows dirt to enter the engine, causing excessive wear and damage.
- It is essential to inspect it before and after each ride or session. Clean if necessary. Clean the filter in a well-ventilated area and ensure that there are no sparks or flames near the work area (including a powerful light source). Do not use petrol to clean the filter, as this may cause an explosion.

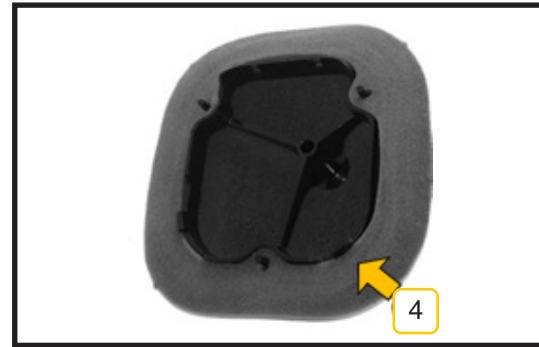



## Transmission oil

For the transmission and clutch to operate properly, keep transmission oil at the right level and change it periodically. A motorcycle with insufficient, deteriorated, or contaminated transmission oil may accelerate wear and cause damage to the transmission.

### ***Checking the oil level:***

1. If you have used the motorcycle, wait for a few minutes.
2. Check the oil level through the level viewer on the bottom right of the engine (1).
3. The oil level must be between maximum and minimum levels.
4. If the level is too high, remove excess through the drain plug (2).
5. If the level is low, add the necessary amount of oil after removing the cap. Use the same type and brand of oil that was already in the engine.

#### **Transmission oil**

GRO RACING 10W50 FULL SYNTHETIC HIGH PERFORMANCE OIL JASO MA2-API SN

#### **Capacity**

800 cc



#### **TIP:**

To achieve proper engine oil temperature and precisely measure the oil level, the engine must be completely cooled, then reheated again for a few minutes at regular operational temperature.



### ***Changing transmission oil:***

Transmission oil must be periodically changed to ensure engine life.

1. Heat the engine for 5 minutes so that the oil lifts any sediment.
2. Stop the engine and put a container under the engine.
3. Remove the oil drain plug (see Checking oil level) and place the motorcycle in usage position to allow all oil to drain.
4. Remove the filler cap (1) to ensure better draining.
5. Thoroughly clean the drain plug magnet.
6. Screw in the oil drain plug with its O-ring. Tighten it to 20 Nm.
7. Remove the filler cap (see Checking oil level) and pour new transmission oil.
8. Check the oil level after activating the kickstart pedal 3 or 4 times.
9. Screw in the oil filler cap.

### **Piston and piston ring**

For this inspection, adjustment, or replacement, please contact your official RIEJU service.

### **Cylinder head, cylinder, and exhaust valve**

For this inspection, adjustment, or replacement, please contact your official RIEJU service.



## Exhaust system

The exhaust and silencer reduce noise and direct gases away from the rider. If the exhaust is damaged, rusted, dented, or cracked, replace it with a new one. Replace the silencer packing if the noise becomes too loud or engine performance decreases.

### ***Exhaust cleaning***

For exhaust pipe cleaning, please see your official RIEJU service.

### ***Silencer replacement***

1. Remove the silencer mounting bolt.
2. Remove the lower mounting bolt (2) from the silencer (3) by pulling backward.
3. Detach the silencer from the joint (arrow).
4. Replace the silencer and reassemble the unit.





## Silencer packing

The RIEJU silencer is an absorption silencer. The absorbent element is the silencer packing. If you detect an increase in exhaust noise, the silencer packing must be replaced.

### ***Silencer packing replacement***

After removing the silencer (see Silencer replacement), remove the 4 screws (1).

1. Remove the inner part of the silencer.
2. Replace the silencer packing (2) by wrapping it around the inner tube.
3. Insert the packing around the exhaust outlet (3) at the rear end of the silencer.
4. Reassemble the unit.

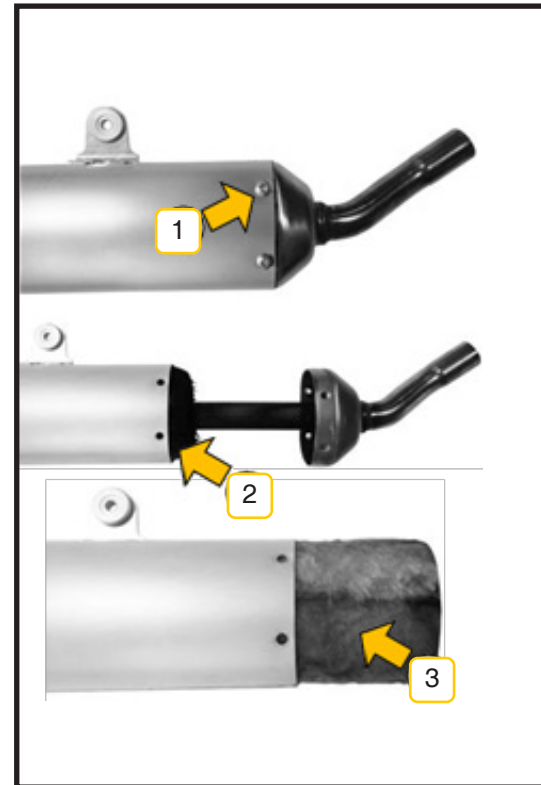

**Connecting rod and bearings**

For this inspection, adjustment, or replacement, please contact your official RIEJU.

**Kickstart pedal and gearshift pedal**

Lubricate moving and articulated parts with oil or grease. Excess lubrication may cause your boots to slip on the pedals.

**Exhaust/silencer rubber joint**

For this inspection, adjustment, or replacement, please contact your official RIEJU.

**Engine bearings**

For this inspection, adjustment, or replacement, please contact your official RIEJU.



## Coolant fluid

Coolant absorbs excess heat from the engine and transfers it to the air through the radiator. If the fluid level decreases, the engine overheats and can be severely damaged. Check the fluid level every day before riding your RIEJU. To protect the aluminium parts of your cooling system (engine and radiator) from rust and corrosion, use chemical inhibitors in the coolant mixture. If you do not use anti-corrosion fluid, the radiator will rust over time. This obstructs the cooling tubes.



### TIP:

- A permanent antifreeze is initially used at the factory.
- It is green in colour, contains 30% ethylene glycol and has a freezing point of  $-18^{\circ}\text{C}$ .



### CAUTION:

- Chemical fluids are harmful to the human body. Follow manufacturer instructions.



### CAUTION:

- Using incorrect fluids may damage the engine and cooling system. Use coolant with specific anti-corrosion properties for aluminium engines and radiators according to manufacturer instructions.

**Overheating damage:**

- Damage caused by overheating to any of the motorcycle's components is not covered by the warranty. We recommend strictly following our use and maintenance instructions to avoid this kind of incident.

**Use for Hard Enduro:**

- For Hard Enduro riding, installation of the specific Hard Enduro kit is mandatory. Riding the motorcycle under extreme conditions without this kit can jeopardise the vehicle's performance and durability.

***Coolant level***

1. Place the motorcycle in normal operating position.
2. Unscrew the radiator cap (1) anticlockwise and wait a few seconds for vapours to escape. Then, tighten and turn in the same direction to fully remove the cap.
3. Check the coolant level. The fluid should be right below the caps' rubber seal.
4. If the fluid level is low, add the required amount through the filler opening.

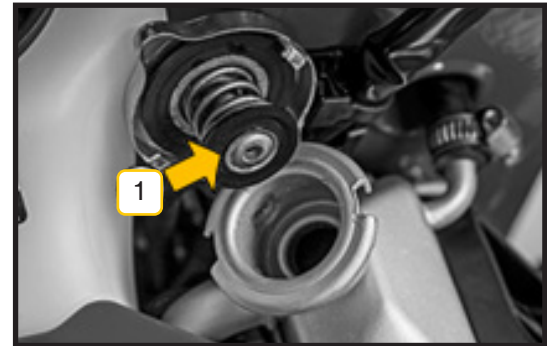
**Recommended fluid**

GRO Antifreeze at 100%



### ***Coolant replacement***

Coolant must be periodically replaced for long engine life.

1. Wait for the engine to completely cool.
2. Place the motorcycle in normal operating position.
3. Remove the cap from the radiator.
4. Place a container under the drain screw (2) located on the bottom of the water pump cover. Drain the fluid from the radiator and engine by unscrewing it.
5. Fill the radiator up to the cap edge and replace the radiator cap.
6. Check for leaks in the cooling system.
7. Start the engine, warm it up, and then stop it.
8. Check the coolant level when the engine has cooled. Add fluid up to the cap if necessary.

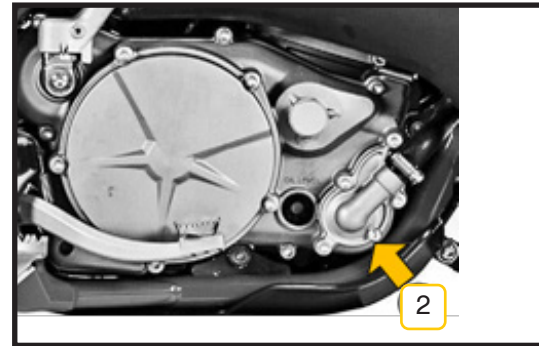

**CAUTION:**

- To avoid burns, do not remove the radiator cap or attempt to change fluid while the engine is still hot. Wait until it cools.

**CAUTION:**

- If fluid falls on the tyres, it makes them more slippery and can cause an accident. Immediately clean fluid that may fall on the frame, engine, or wheels.
- Inspect old fluid. If you see white spots in the fluid, this means that the cooling system's aluminium parts are corroded. If the fluid is brown, the system's steel or iron parts are rusted. In both cases, clean the system.

**CAUTION:**

- Tighten the water pump drain screw to 9 Nm. Replace gaskets with new ones. Check for possible damage, leakage, or missing gaskets in the cooling system. Cold countries must adjust the antifreeze capacity to their minimum temperature with a -5°C margin.



## Radiator hose and connections

### ***Radiator hoses***

Check that the radiator hoses are not cut or deteriorated and that the connections do not leak.

### ***Radiator***

Check that radiator fins (1) are not blocked (insects or mud). Clean blockage with a low-pressure water jet.



#### **CAUTION:**

- Using high-pressure water can damage the radiator fins and reduce effectiveness.
- Do not block or divert air intake into the radiator by installing unauthorised accessories. Interference to the radiator can overheat and damage the engine.



## Brake adjustment

### **Front brake lever:**

Adjust the brake lever (1) until it feels comfortable. To adjust it, loosen the nut (2). After adjusting, tighten securely.

Check that the brake responds correctly.

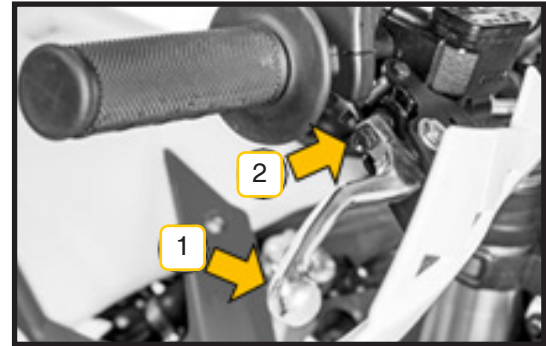

### **Rear brake pedal:**

When the brake pedal (3) is in resting position, it should have 5-7 mm play.

Check that the brake responds correctly and does not create friction.

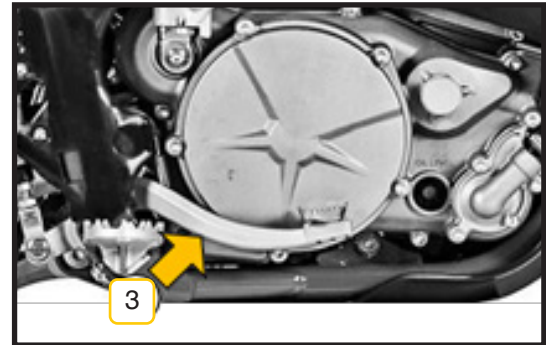



**CAUTION:**

- If the pedal or brake lever is spongy when activated, there may be air in the pump or circuit for each brake, or a component of the braking system may be in poor condition.
- Since it is dangerous to ride under these conditions, check the brakes immediately. We recommend going to your official RIEJU service.



## Brake wear

If any of the front or rear brake disc pads are less than 1mm thick, you must completely replace the affected set of pads.



### CAUTION:

- Verify that the front discs are at least 3 mm and the rear discs are 3.5 mm.



### CAUTION:

- For this replacement, we recommend going to your official RIEJU service, who can also check for possible wear on your brake discs.

### ***Front brake pad replacement:***

To replace the front brake pads, follow these steps:

1. Loosen the pin (1) and remove.
2. Remove the pads (2).

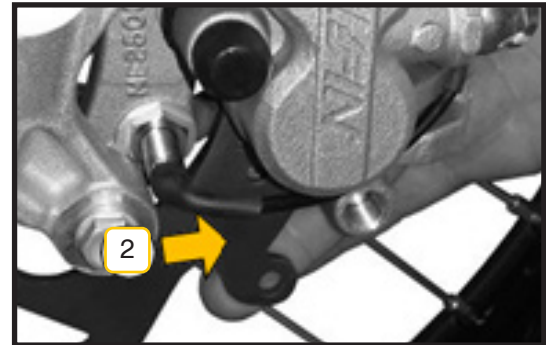
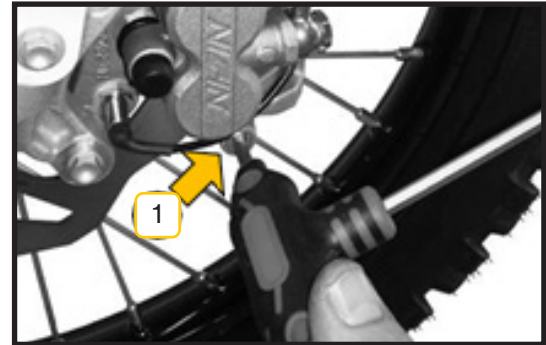



3. Put a piece of paper or rag around the brake fluid tank to prevent spillage. Loosen the screws (3) to open the cover.



**TIP:**

For better access, we recommend loosening the screw (4) and rotating the throttle grip.

4. Remove the cover (5) and ensure that no brake fluid spills outside the tank.

5. Push back the two calliper pistons. Take care not to damage them.

6. Install the new pads.

7. Put the pin in place.

8. Put the tank cap on.

9. Activate the brake lever several times until it has the correct feel.

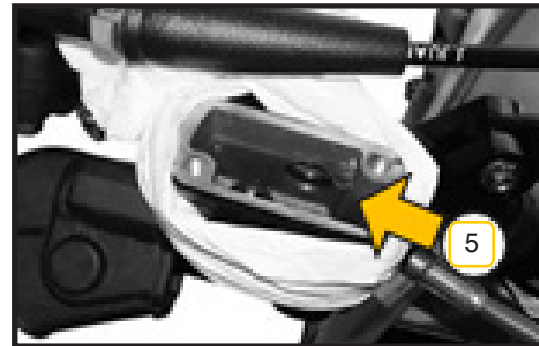
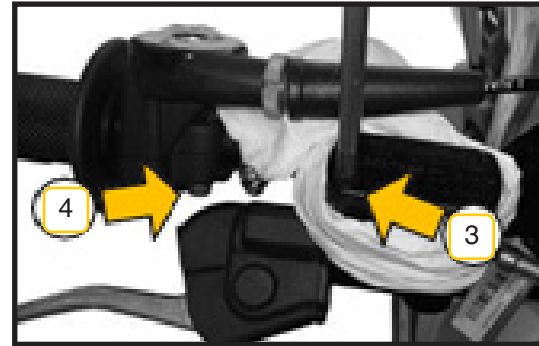

**Rear brake pad replacement:**

To replace the rear brake pads, follow these steps:

1. Remove the pin protector (1).

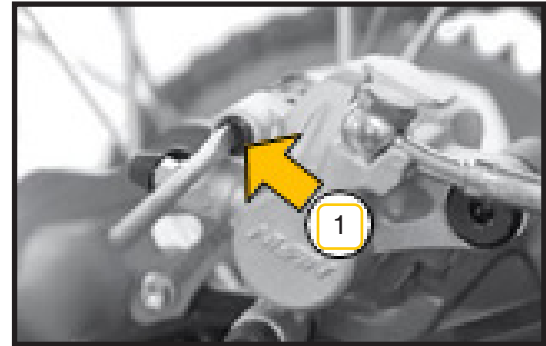

2. Loosen and remove the pin (2).

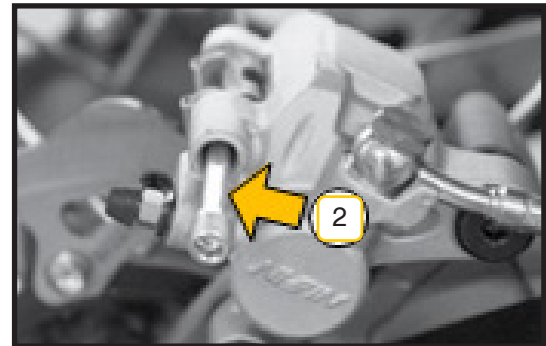



3. Loosen and remove the pin (2).

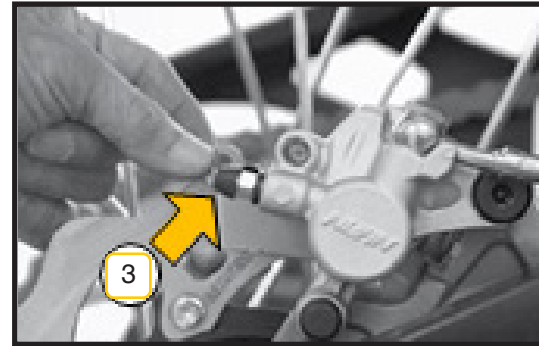

4. Set aside the small metal plate (4) and the fibre plate (5) in case the new pads do not include them.

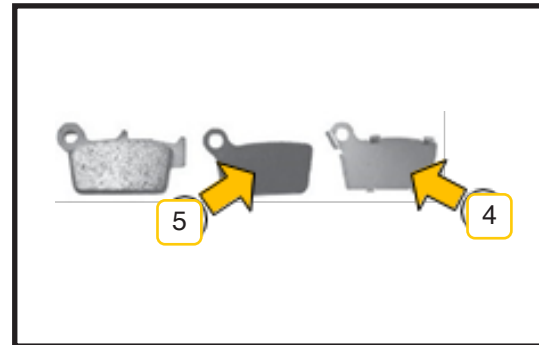



5. Set aside the small metal plate (4) and the fibre plate (5) in case the new pads do not include them.

**TIP:**

Put a piece of paper or rag around the brake fluid tank to prevent spillage.

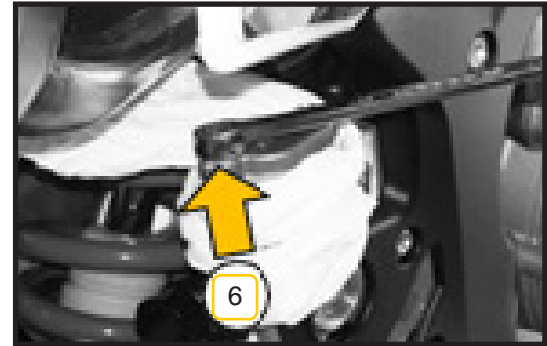

6. Push back the calliper piston. Take care not to damage it.

7. Install the new brake pads.

8. Refit the pin and its protector.

9. Put the tank cap on.

10. Activate the brake pedal several times until it has the correct feel.

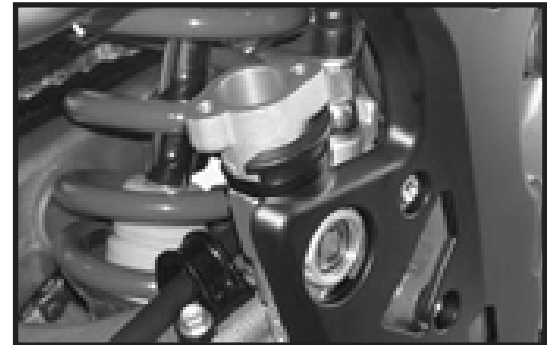



## Brake fluid

Periodically inspect brake fluid and replace it. You must also replace it if it appears contaminated with water or dirtiness.

### Recommended fluid

GRO DOT4

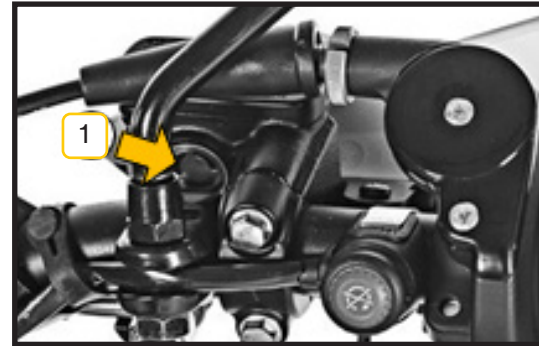

## Brake fluid level

The front (1) and rear (2) brake fluid tanks must be at least half full. If fluid is missing, it must be added.



### CAUTION:

- Check that no fluid is leaking through the gaskets.
- Check for possible damage to brake hoses.



### CUIDADO:

- Do not dump brake fluid onto painted surface.

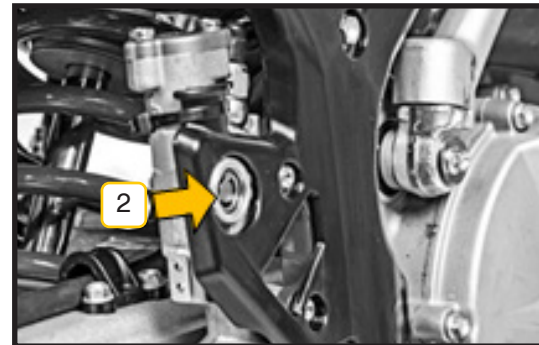



### **Brake master cylinder piston and dust seal (front and rear)**

For this inspection, adjustment, or replacement, please contact your official RIEJU.

### **Brake calliper piston and dust seal (all callipers)**

For this inspection, adjustment, or replacement, please contact your official RIEJU.

### **Brake hoses**

For this inspection, adjustment, or replacement, please contact your official RIEJU.

### **Spokes and rims**

The spokes must be evenly tightened with no play, because this would misalign the rim. The other spokes would be affected and could break.

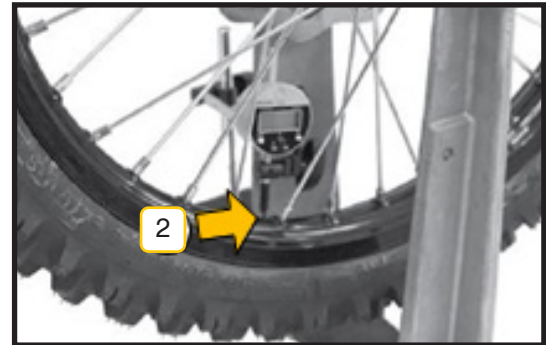



### **Rim truing:**

Place a dial gauge next to the rim (1) and turn the wheel to measure axial runout.

Place the gauge inside the circumference of the rim (2), turn the wheel, and the difference between the highest and lowest readings is the runout.

If slightly out of true, this can be corrected by tightening or loosening a few spokes with a spoke wrench (3). If the wheel is bent or curved, it must be replaced.

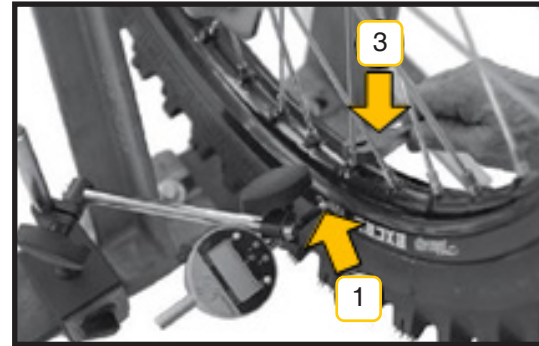

#### **CAUTION:**

- A welded area on the wheel may bear excessive runout. Ignore this when measuring runout.



#### **CAUTION:**

- Actions on rims and spokes require a specialist. We recommend contacting your official RIEJU service.



## Chain guide

Lubricate the chain guide (4) with the same product you used to lubricate the chain.

## Chain guide wear

Check the condition of the chain guide's inner faces, where the chain runs. Depending on their condition, it may need to be replaced.

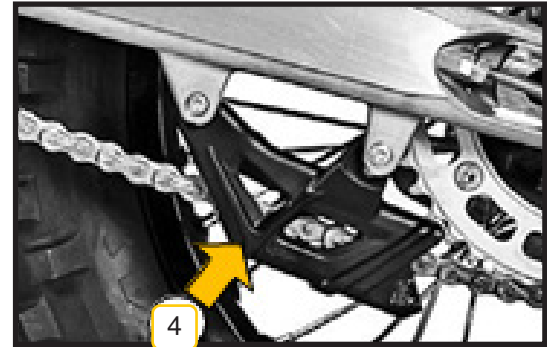

## Chain guide slider

Visually inspect the top and bottom part of the chain slider (5) on the swingarm (6). If worn out or damaged, replace it.

Lubricate the guide slider with the same product you used to lubricate the chain.

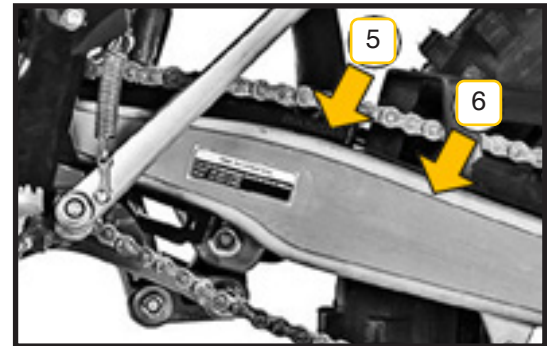



## Front suspension

### ***Bleeding air from front suspension***

To bleed air from the front suspension, follow these steps:

1. Place the motorcycle on a stand or stable support. The front fork must be fully extended.



### ***Fork spring replacement***

Please follow the steps below if you need to replace the front fork spring:

1. Remove from the fork leg from the suspension clamps.
2. Loosen the upper fork nut.
3. Drain the oil from inside the fork.
4. 4. Loosen the lower fork nut.





5. Remove the internal cartridge.

6. Remove the spring.

Replace the spring and follow these steps in reverse order to reassemble.



**CAUTION:**

- Ensure that the brake and clutch fluid tanks remain vertical at all times. Otherwise, both systems must be bled again.

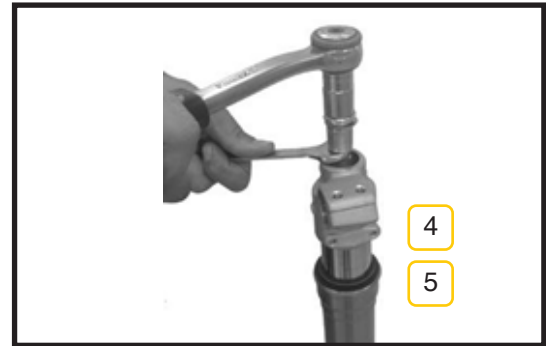

4

5

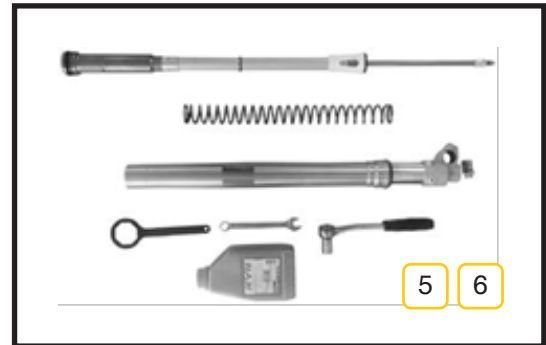

5

6



## Front suspension oil

### ***Adjusting oil volume***

To adjust the oil volume, you must first remove the spring. To do so, follow the steps described in “Fork spring replacement.” Use a graduated measuring cup for fluids and fill to the specified volume of the recommended oil (for each bottle). Slowly pour the oil from the measuring cup inside the fork tube.

Next, and to ensure proper bleeding of the hydraulic system, gently and alternately push the rod through its full travel (up and down), several times, until it reaches its limits. Reassemble the entire fork cap assembly. You must strictly observe the fill volume. This determines the oil level inside the fork and correct operation



#### **Recommended fluid**

KYB: KYB 01M

#### **KYB Ø46 fork**

#### **Open cartridge suspension oil level:**

105 mm

#### **KYB Ø48 fork**

#### **Open cartridge suspension oil level:**

350 mm



### **ADVERTENCIA:**

- Riding with a damaged fuel hose or simply starting the engine can cause fire and the resulting accident (and resulting injuries).
- ALWAYS USE THE ORIGINAL FUEL HOSE. YOUR OFFICIAL RIEJU SERVICE WILL PROVIDE THIS.



## Fuel system

Check the condition of: The fuel cap seal, the fuel cap, the tank breather hose, and the fuel tank.

## Steering play

Steering play be kept adjusted so that the handlebar turns freely, but without play.

To check steering adjustment, lift the motorcycle from the ground, using a stand under the frame. Move the handlebar gently in each direction. If, when you release the handlebar, it continues moving on its own, this means that the steering is not too tight. Crouch in front

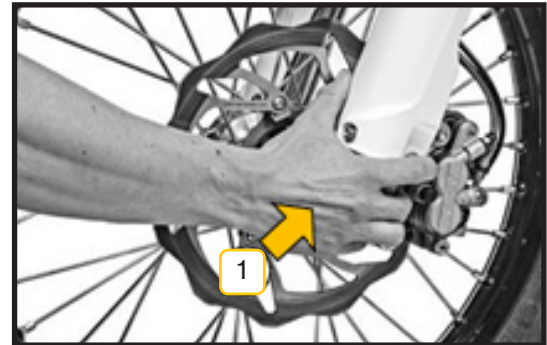



of the motorcycle, grab the lowest part of the front fork (on the axle) and stretch the fork (1). If there is play, steering is too loose.

If you must adjust steering:

1. Stabilise the motorcycle with the stand or special bench.
2. Keep the front wheel off the ground.
3. Remove the handlebar by loosening the handlebar clamp bolts (2) and removing the upper clamps.
4. Loosen the steering stem nut (3).
5. Turn the steering adjustment nut (4) with the special key to reach proper adjustment.
6. Tighten the steering stem nut.
7. Check steering again and readjust if necessary.
8. Reinstall the removed parts.

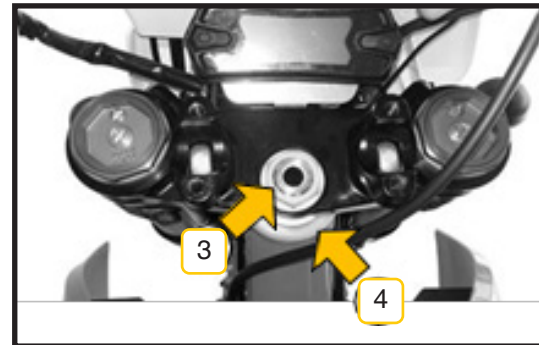
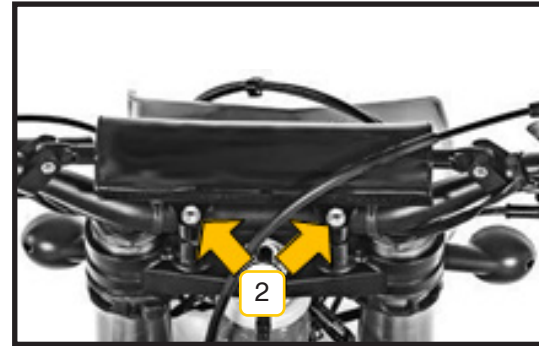



## General lubrication

Periodically lubricate the displayed parts or whenever the vehicle has been exposed to water, especially after using high-pressure water. Before lubricating each part, clean the rusted parts with anti-corrosion product and remove any remaining grease, oil, or dirt.

- Clutch lever (1)
- Front brake lever (2).
- Rear brake pedal (3).
- Rear brake pedal bushing (4).

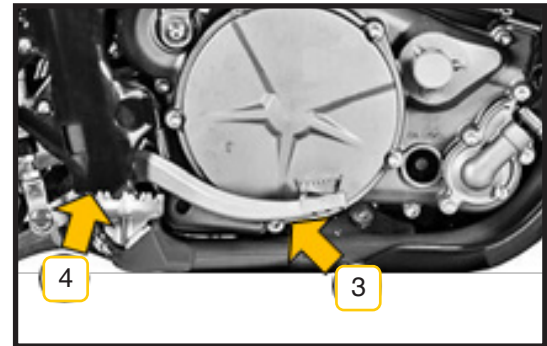
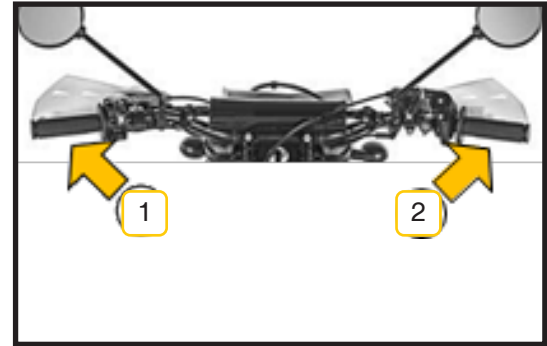



- Shift lever (5).

Use aerosol with a tube to lubricate with pressure.

Use grease inside the throttle cable.

### ***Adjusting oil volume***

This is necessary after driving on wet ground and when the chain looks dry.

This chain is roller, so a specific lubricant should be used for this type of chain. Your official RIEJU service will be delighted to provide this to you.

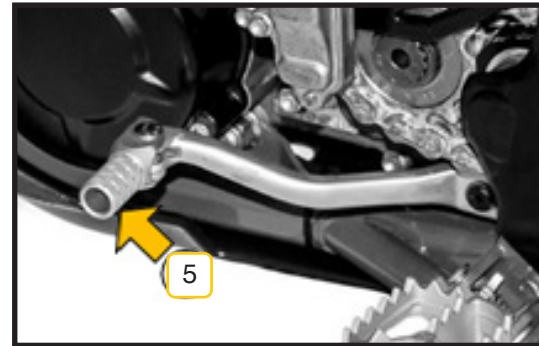

**Steering bearing**

For this inspection, adjustment, or replacement, please contact your official RIEJU.

**Wheel bearing**

For this inspection, adjustment, or replacement, please contact your official RIEJU.

**Swingarm and linkages**

For this inspection, adjustment, or replacement, please contact your official RIEJU.



## Rear suspension

### ***Shock absorber oil change***

For this inspection, adjustment, or replacement, please contact your official RIEJU service.

### ***Shock absorber disassembly***

To remove the rear shock absorber from the frame, please follow these steps:

1. Stabilise the motorcycle with the central stand or special bench.
2. Keep the rear wheel off the ground with a block.
3. Loosen the exhaust mounting bolts (1).

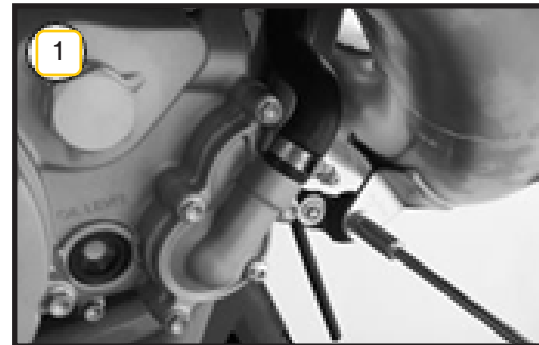



4. Remove the exhaust springs (2).



5. Unscrew the shock absorber from the lower end of the rocker (3).

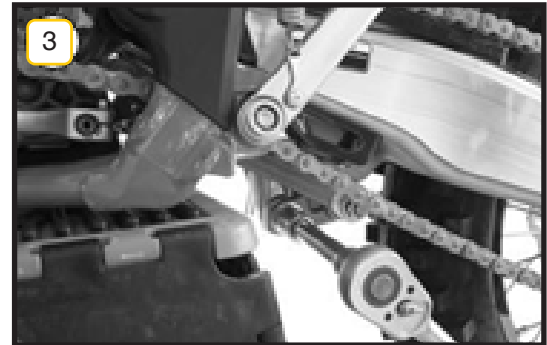



6. Remove the screw and release the rocker (4).



7. Loosen the upper shock absorber screw from the frame (5).





8. Remove the upper screw mounting the shock absorber to the frame (6).



9. Carefully remove the shock absorber from the right side of the motorcycle as displayed in the photograph (7).





## Chain

The secondary drive (chain, sprocket, rear sprocket, guide, and guide slider) of your motorcycle works under very intense conditions. This is also one of the most important assemblies for your SAFETY.

It requires ongoing and, obviously, proper maintenance.

### ***Chain tension***

1. Motorcycle unloaded and with side stand deployed: There must be a space of 30-36 mm between the chain and the swingarm in the area behind the guide slider. Without applying excessive force, you can check this with your fingers.
2. Loosen the rear axle nut (3).
3. Find the point of maximum chain tension.





4. With the adjustment nuts (2), align the chain at both ends of the swingarm by matching the notches on the swingarm with the pins on the adjusters.
5. Tighten the nuts (2).
6. Tighten the rear axle nut (1).
7. Check at the maximum tension point again. Readjust if necessary.

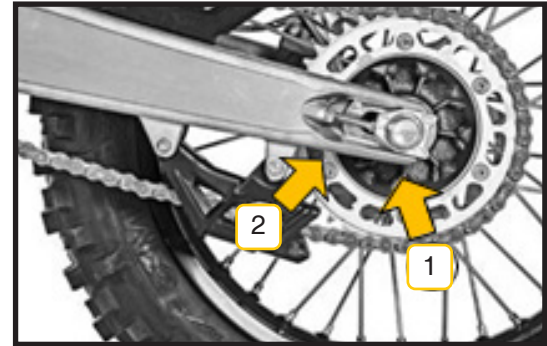

You must constantly check chain tension. When doing so, you must also visually inspect the condition of the chain, guide slider, guide, sprocket, and rear sprocket.

In general terms, when the chain has been overused, stretched by more than 2%, it must be replaced. This is usually the appropriate time to replace the guide slider, guide, sprocket, and rear sprocket. This is for practical, economic, and SAFETY reasons.

A chain at the limit of its use will have partially worn the teeth of the sprocket and rear sprocket, guide, etc.



If a new chain has been installed, but the other components have not been replaced, their lifespan will be reduced by 40% and already-worn components, such as the sprocket and the rear sprocket, will wear out quickly. Medium- and long-term, it is more economical and safer to replace the complete drive kit with each chain replacement. Your official RIEJU service will be delighted to provide this to you.

Lubrication: Your chain is the sealed type. This requires special lubricant. Use the same lubricant for the chain guide, guide slider, sprocket, and rear sprocket.



**TIP:**

We recommend always keeping the chain properly lubricated. Chains that are allowed to dry, that are lubricated, then left to dry, over and over, greatly shorten their lifespan and the lifespan of the components around them.



## Tyres

Check that the tyres are not worn, cracked, or damaged. If they are, replace them with new tyres that match specifications in the technical sheet, with at least the minimum load and speed:

Minimum load and speed rating
Front tyre: 41J
Rear tyre 52J



Periodically check that they are at the right pressure.

Recommended pressure
1,2 bar - (Normal use)
1 bar - (competition only)



## Battery charge

The battery (HJTZ7S-FPZ) is maintenance-free.

Battery		
HJTZ7S-FPZ		
Capacity	Voltage	Maximum charge
4.5 Ah	12.8 V	14.4 V / 270cca



## Battery replacement

The battery is located under the saddle, inside the battery box. Follow these steps to replace it:

1. Loosen the seat mounting screw (1) and remove it by gently pulling backward.
2. Loosen the battery terminals (2) and remove it.

Replace the battery with a new one and follow the steps in reverse order to assemble it.





### **Battery charger information**

- Minimum voltage before beginning the charging process: 9v.
- When charge is complete, unplug the battery charger.
- Once charged, leave the battery between 1 and 2 hours before checking voltage. If below 10v, replace it.
- Recharge battery periodically.
- If you do not use the motorcycle, recharge every 3 months.



#### **CAUTION:**

- Use the charger for lithium batteries with the following specifications:

12.8V LiFePO4 Battery  
 A C Input Voltage 100-240V 50/60Hz  
 Output Voltage 14.2V  $\pm$  0.2V  
 Output current 2A  $\pm$  0.1A



#### **CAUTION:**

- Do not tamper with or attempt to open the battery. The electrolyte and gases are toxic and can cause serious injury.
- Keep the battery out of reach of children.

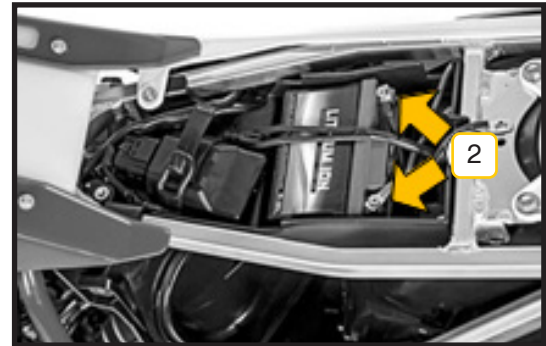



## ADJUSTMENTS

### Introduction

The adjustments chapter is intended for users with advanced mechanical knowledge and experience. If this is not you, your official RIEJU service should carry out these adjustments.

### Secondary drive

Secondary drive may be modified by changing the rear and/or front sprockets. RIEJU has the following sprocket sizes available:

Rear sprockets: 39, 40, 42, 44, 46, 47, 48, 49, 50, 51, 52.

Front sprockets: 12, 13.

If gearing is shortened, your RIEJU will lose top speed but gain in acceleration and at low speeds. It will be more manageable on difficult terrain.



#### **CAUTION:**

Pay attention to engine RPM.

If gearing is lengthened, your RIEJU will gain top speed but lose acceleration and manageability at low speeds.



## Front suspension

Your motorcycle has adjustable suspension. The available adjustments are:

- Extension damping (3) - located on the bottom of the fork.
- Compression damping (2) - located on the top of the fork.
- Air bleed (1) - located on the top of the fork.
- Oil volume - 350 ml. (KYB 010M Oil).

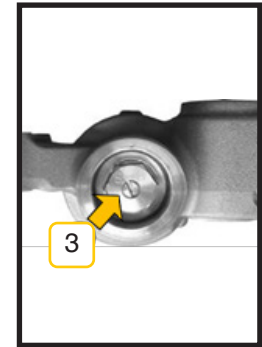
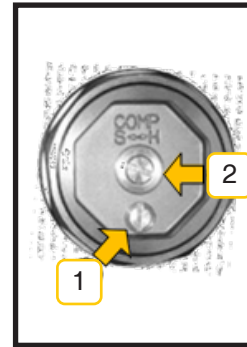



The volume of oil in the fork affects the internal oil level and can be adjusted. Changing the volume, and therefore the level of the oil, does not affect the first part of the suspension travel, but it does affect the final part.

When you increase the oil volume/level, suspension becomes more progressive and the front fork's action is firmer at the end of travel.

When you decrease oil volume/level, suspension is less progressive and fork action is less firm at the end of travel.

If bottoming out occurs, we recommend slightly increasing the oil level (approx. 10 ml).

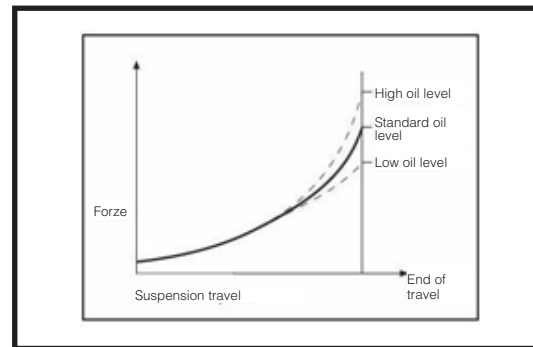

**CAUTION:**

- Ensure that both fork legs have the same oil volume/level to keep behaviour consistent.



## Front suspension adjustments

<b>Spring</b>	from 65 to 75kg.	50 N/mm
	from 75 to 85kg.	52 N/mm (STD)
	from 85 to 95kg.	54 N/mm
<b>Rebound</b>	Comfort	12 clicks from fully closed
	Standard	10 clicks from fully closed
	Sport	8 clicks from fully closed
<b>Compression Low Speed</b>	Comfort	14 clicks from fully closed
	Standard	12 clicks from fully closed
	Sport	10 clicks from fully closed
<b>Compression High Speed</b>	Comfort	1-6/8
	Standard	1-3/8
	Sport	1



## Rear shock absorber

- Extension damping (3) - located on the bottom of the fork.
- Compression damping (2) - located on the top of the fork.
- Air bleed (1) - located on the top of the fork.
- High-speed compression 17 mm - located on top of the shock absorber (4).
- Standard spring preload (3) -248 mm, adjustable between 248 and 255 mm between seating surfaces.
- Spring rate: 52N/m - ideal rider weight 75-85 kg.



Standard	260 mm
Range	243-255 mm
Setting length	248 mm

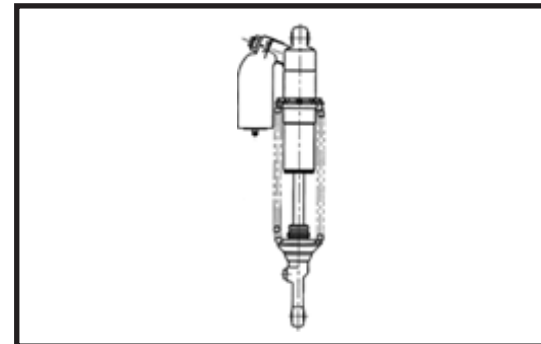



### ***Initial static adjustment (SAG)***

To adjust suspension sag, please follow these steps.

1. Place the motorcycle on a stand so the rear wheel remains off the ground in a stable position.
2. Measure the vertical distance (1) between the rear axle nut and a fixed upper joint.
3. Lower the motorcycle from the stand and place it with both wheels on the ground (not resting on the kickstand or side stand).
4. Measure the vertical distance (1) between the rear axle nut and a fixed upper joint again.

If the difference between the measurements is not  $35 \pm 5$  mm, adjust shock absorber preload until you reach this value.

Sag with the rider seated on the motorcycle should be  $100 \pm 5$  mm.

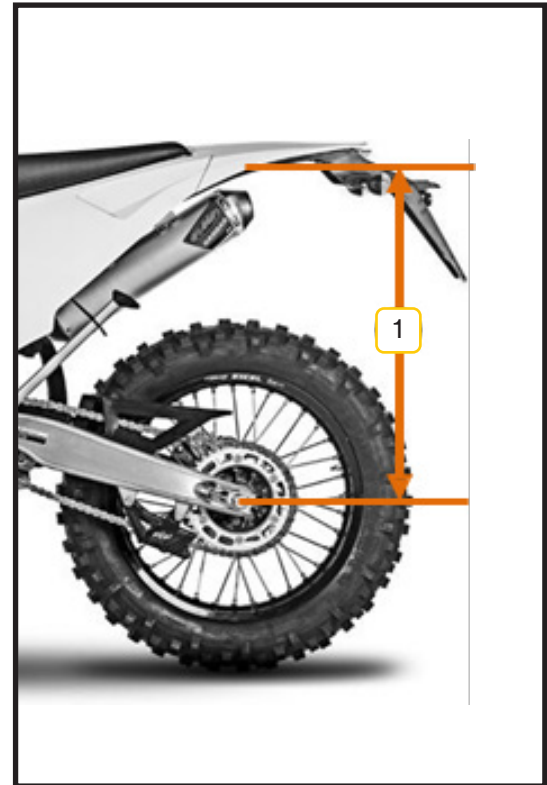



### ***Adjustment based on type of terrain***

Always start from standard settings and only make changes if necessary.

- **Hard terrain:**

Soften compression damping settings on both the fork and the shock absorber.

- **Sandy terrain:**

Stiffen compression damping or replace the fork spring with a stiffer one. Increase compression and especially rebound on the rear shock. Reducing spring preload may also help.

- **Muddy terrain.**

Stiffen compression damping or replace the fork spring with a stiffer one. Increase compression and especially rebound on the rear shock. Increasing spring preload may also help.



## ***Adjusting your motorcycle***

### **Compression**

- If the motorcycle wallows or oscillates excessively, even at low speed and when obstacles are small, has a low riding position, or tends to bottom out on descents, you must stiffen compression settings on both the fork and the shock absorber. If this does not correct the matter, it may be an indication of a spring that is too soft or worn, or of SAE oil with too low a viscosity or insufficient internal level.
- If the motorcycle feels hard, especially over a series of bumps, along with lack of rear wheel traction and strong impacts from irregularities, you must soften compression settings on both the fork and the shock absorber. If this does not correct the matter, it may be an indication of a spring that is too stiff or an excessive level of oil in the fork.

### **Rebound**

- If the motorcycle feels unstable or soft, it loses its line easily, or oscillates excessively, even at low speeds and with small obstacles, you must stiffen rebound settings on both the fork and the shock absorber. If this does not correct the matter, it may be an indication of a spring that is too soft or worn, or of SAE oil with too low a viscosity or insufficient internal level.
- If the motorcycle feels stiff and with short suspension travel, along with lack of rear wheel traction and strong impacts from irregularities, you must soften rebound settings on both the fork and the shock absorber. If this does not correct the matter, it may be an indication of a spring that is too stiff or an excessive level of oil in the fork.



### CAUTION:



- Only make one adjustment at a time and test the effect it has on the motorcycle.
- Suspension adjustment is a very critical adjustment. If not performed correctly, it can prevent even the best rider from reaching full performance on the motorcycle. Check suspension according to the rider and the conditions of the terrain.
- When fine-tuning suspension, do not forget:
  - If the motorcycle is new, get used to the suspension for at least one hour of riding before you make any changes.
  - The factors to consider are the rider's weight, rider's skill level, and conditions of the terrain.
  - If you have any problems, try changing your position on the motorcycle to alleviate them.
  - Suspension should be adjusted to the rider's strong points. If fast on curves, you should adjust suspension to suit this.
  - Make changes in small increments. It is very easy to over-adjust.
  - Front and rear suspension must be balanced.
  - When evaluating suspension, the rider must make an effort to ride conscientiously and recognise the effects of the change. Improper rider position and/or fatigue can lead to incorrect judgement of the adjustments.
  - When a setting works for a certain terrain, take note of settings for future reference when you encounter similar terrain.
  - Lubricate swingarm bearings, linkages, rocker, and joints before making changes to prevent excess friction that would affect suspension performance.



## TROUBLESHOOTING

ERROR	CAUSE	SOLUTION
The engine does not turn.	Crankshaft seized.	Please see your official RIEJU service.
	Cylinder/piston/connecting rod seized.	Please see your official RIEJU service.
	Transmission set seized.	Please see your official RIEJU service.
The starter motor does not turn. <sup>1</sup>	The starter relay fuse is blown.	Remove seat and check fuse.
	The battery is discharged.	Remove seat and check fuse.
The engine does not start.	Motorcycle has been inactive for a long period.	Drain old fuel from tank. When tank is filled with fresh fuel, engine should start immediately.
	Dirty or wet spark plug.	Clean or dry spark plug. Replace if necessary.
	Engine flooded.	To clear flooded engine, turn off fuel, remove spark plug, engage a gear, and push motorcycle several metres with throttle open. You will visually know when pre-compression crankcase has been emptied. Reinstall spark plug and start engine. You may need to remove spark plug again if pushing motorcycle was insufficient. If plug is wet, clean it. Push again, reinstall plug, and engine should start
 <b>CAUTION:</b>		<ul style="list-style-type: none"> <li>• For your safety, wrap spark plug cap with dry cloth. This avoids possible sparking.</li> </ul>



The engine does not start.	Incorrect air/fuel mixture.	Clean fuel tank vent. Adjust air filter duct.
	Incorrect air/fuel mixture.	Check exhaust valve and correct.
Engine starts but then stops.	Incorrect air supply.	Close choke. Clean fuel tank vent tube. Adjust air filter duct.
	Lack of fuel.	Fill fuel tank.
Engine starts but then stops.	Low coolant.	Add coolant. Check cooling system for leaks.
	Blocked or dirty radiator.	Clean radiator fins or replace radiator.
Engine starts but then stops.	Dirty, broken, or improperly adjusted spark plug.	Check condition of spark plug and, if necessary, clean, adjust, or replace it.
	Issue with spark plug cap.	Check condition of spark plug cap. Ensure proper contact between high-tension cable and cap and the cable itself. Replace worn components.
	Damaged ignition rotor.	Replace rotor.
	Water in fuel.	Empty tank and fill with new fuel.



Engine lacks power or accelerates poorly.	Fuel supply defective.	Clean fuel system and check it.
	Dirty air filter.	Clean or replace air filter.
	Exhaust damaged or leaking.	Check if exhaust system is damaged. Renew fiberglass in silencer if necessary.
	Carburetor jets dirty.	Remove carburetor and clean jets.
	Worn or damaged crankshaft bearings.	Please see your official RIEJU service.
Engine makes strange sounds.	Ignition problem.	Please see your official RIEJU service.
	Overheating.	see "Engine overheating"
Exhaust backfires.	Carbon deposits in combustion chamber.	Please see your official RIEJU service.
	Poor-quality fuel or incorrect octane rating.	Drain fuel and refill with fuel of correct octane.
	Poor-quality fuel or incorrect octane rating.	Replace with another correct spark plug.
	Deteriorated exhaust system gaskets.	Check if exhaust system is deteriorated. Gaskets must be in perfect condition. If not, replace them with new ones.
Exhaust emits white smoke.	Deteriorated cylinder head (coolant leaks into cylinder).	Please see your official RIEJU service.



Exhaust emits black smoke.	Blocked air filter.	Clean or replace air filter.
	Main jet too high.	Check main jet.
Gears do not engage.	Clutch does not release.	Please see your official RIEJU service.
	Shift fork bent or stuck.	Please see your official RIEJU service.
	Gear stuck in transmission.	Please see your official RIEJU service.
	Shift lever damaged.	Replace shift lever.
	Selector position spring loose or broken.	Please see your official RIEJU service.
	Shift drum broken.	Please see your official RIEJU service.
	Shift ratchet spring broken.	Please see your official RIEJU service.
Gears slip out.	Worn shift fork.	Please see your official RIEJU service.
	Worn gear slot.	Please see your official RIEJU service.
	Broken gears.	Please see your official RIEJU service.
	Damaged gear dogs.	Please see your official RIEJU service.
	Worn shift fork shaft.	Please see your official RIEJU service.
	Broken selector position spring.	Please see your official RIEJU service.



Clutch slips.	Excess clutch fluid level.	Check level and adjust if necessary.
	Worn clutch plates.	Please see your official RIEJU service.
	Broken or weak clutch spring.	Please see your official RIEJU service.
Motorcycle is unstable.	Cable hinders handlebar rotation.	Move cable aside.
	Steering stem nut very tight.	Adjust steering stem nut.
	Damaged or worn steering bearings.	Please see your official RIEJU service.
	Bent steering stem.	Please see your official RIEJU service.
Suspension is too stiff.	Excessive oil level in fork.	Remove excess oil to correct level.
	Front fork's oil too viscous.	Drain fork oil and refill with oil of correct viscosity.
	Twisted front fork.	Please see your official RIEJU service.
	Too much tyre pressure.	Check tyre pressure.
	Improperly adjusted suspension.	Adjust suspension.



Check level and adjust if necessary.	Low oil level in fork.	Supports, nuts, or bolts improperly tightened.
	Front fork's oil too low viscosity.	Drain fork oil and refill with oil of correct viscosity.
	Low tyre pressure.	Check tyre pressure.
	Improperly adjusted suspension.	Adjust suspension.
Motorcycle makes abnormal noises.	Improperly adjusted chain.	Adjust chain tension.
	Worn chain.	Replace chain, rear sprocket, and pinion of secondary drive.
	Worn rear sprocket teeth.	Replace rear sprocket.
	Insufficient chain lubrication.	Lubricate chain with suitable lubricant.
	Misaligned rear wheel.	Check wheel spokes' tension. Readjust if necessary.
	Weak or broken front fork spring.	Replace front fork spring.
	Worn brake disc.	Replace brake disc.
	Incorrectly fitted, worn, or glazed pads.	Refit or replace pads.
	Damaged cylinder.	Please see your official RIEJU service.
	Supports, nuts, or bolts improperly tightened.	Check and tighten to correct torque.



Handlebars vibrate.	Worn tyre.	Replace tyre.
	Swingarm or needle bearings worn.	Please see your official RIEJU service.
	Wheel out of true.	Please see your official RIEJU service.
	Misaligned wheels.	Check wheel spokes' tension. Readjust if necessary.
	Excessive play in steering stem.	Check and adjust steering bearing clearance.
	Loose handlebar clamp, loose steering nut.	Check and tighten to correct torque.
Motorcycle tends to lean to one side.	Twisted frame.	Please see your official RIEJU service.
	Improperly adjusted steering.	Check steering play adjustment.
	Twisted steering stem.	Please see your official RIEJU service.
	Twisted front fork.	Please see your official RIEJU service.
	Misaligned wheels.	Check wheel spokes' tension.
Brakes do not function properly.	Worn brake discs.	Replace discs.
	Brake fluid loss.	Please see your official RIEJU service.
	Deteriorated brake fluid.	Please see your official RIEJU service.
	Broken master cylinder piston.	Please see your official RIEJU service.
	Worn brake pads.	Check and replace pads if necessary.



Bulbs burn out.	Defective voltage regulator.	Please see your official RIEJU service.
Lighting system does not work.	Damaged connectors, regulator with inadequate voltage output, check stator voltage.	Clean/replace connectors, check regulator, check stator voltage.



## VEHICLE STORAGE AND CLEANING

### Vehicle storage

If your motorcycle will not be used for an extended period, special maintenance is required and certain materials, tools, and technical expertise are necessary. We therefore recommend that these operations be performed at an authorised **RIEJU** dealer.

If you wish to carry out these procedures yourself, please follow the methods described as follows:

- Completely replace the oil with new oil.
- Block the air filter intake and the exhaust outlet with a cloth soaked in clean oil to prevent humid air from entering the engine.
- Completely drain all the fuel from the fuel tank.
- Remove the battery, clean its surface with neutral soapy water, and remove any rust from the positive and negative terminals.
- Store the battery in a room at a temperature above 0 °C.



- ☒ Adjust the tyre pressure to the specified value.
- ☒ Thoroughly wash the vehicle.
- ☒ Spray a rubber protectant on the surface of all rubber parts.
- ☒ Coat the entire vehicle with automotive protective wax.
- ☒ Finally, cover the vehicle with a cloth and store it in a dry, well-ventilated area.



**CAUTION:**

- Recharge the battery you have removed once per month.



## How to reactivate the vehicle

- ☒ Thoroughly clean the vehicle.
- ☒ Remove the cloths from the air filter intake and the exhaust outlet.
- ☒ Completely replace the engine oil and oil filter.
- ☒ Install the battery.
- ☒ Start the vehicle.



## Vehicle protection

Depending on how you use it, wash the vehicle frequently and keep it clean and dry.

Remove any dirt or residues such as bird droppings, asphalt, or salt from the surface as soon as possible.

Attempt to use a vehicle cover. Prolonged exposure to sunlight may cause ageing and discolouration of exterior parts.

## Cleaning the vehicle

- Cover exhaust system to prevent water from entering.
- Cover the anti-theft lock on steering lock with insulating tape.
- Remove mud and dirt with a low-pressure water jet.
- Clean especially dirty areas with a special cleaner for motorcycles.
- Rinse with a low-pressure water jet.
- Allow motorcycle to drain naturally.
- Take a short ride with the motorcycle under engine reaches operating temperature.
- Lubricate the chain and other components that require lubrication (see maintenance section).

**CAUTION:**

- Never clean the vehicle with high-pressure equipment. Avoid spraying directly on the multi-function display, coil, spark plug cap, carburetor, switches, levers, and all other electrical components.

**CAUTION:**

The braking performance of wet brakes is reduced. Test the braking system repeatedly at low speed after washing to dry it quickly.

**CAUTION:**

- The ABS module is located under the fuel tank. When cleaning the vehicle, do not direct water directly onto the ABS module to avoid damage.

**CAUTION:**

Do not apply de-greaser to the wheel axles or the chain.



**CAUTION: RIEJU** accepts no responsibility for the use of corrosive degreasers that may stain or damage motorcycle parts. **RIEJU** is not liable for any damage or defects caused by using high-pressure water to clean the motorcycle.



## MODIFICATIONS AND ACCESSORIES

Only use original **RIEJU** parts and accessories.

You can obtain genuine parts, accessories, and other **RIEJU** products through authorised dealers. At the same time, professionals will advise you on installation and use.

The safety, performance, and compatibility of these parts and products have been tested and are guaranteed. On the other hand, no responsibility will be accepted for unauthorised parts or accessories.

Whenever you plan to replace parts, ensure compliance with all laws and regulations so that your vehicle meets national road vehicle requirements and other legal and technical specifications.



### **CAUTION:**

- The unauthorised modification of components, such as the electronic control system, may cause vehicle damage and accidents.



## WARRANTY

Standards regulating manufacturer **RIEJU'S** warranty.

The company **RIEJU** hereby guarantees the end consumer, purchaser of a vehicle manufactured by **RIEJU**, that both the materials and the manufacturing are free from defect, pursuant to the highest quality standards. Consequently, **RIEJU** hereby provides the end purchaser (hereinafter, the "purchaser"), pursuant to the conditions set forth below, with a warranty to repair all material or manufacturing defects found on a new motorcycle at no cost, within the established warranty period and with no limitation in terms of the number of kilometres travelled or the number of hours the vehicle has been operated.

### Warranty Period

The warranty period shall be governed by warranty law in the vehicle's country of sale, in force at the time it is sold.



Warranty claims for defects not brought to the attention of a **RIEJU**-authorised dealer before the end of the warranty period shall be excluded.

### Purchaser obligations

**RIEJU** may legitimately reject warranty claims if, and to the extent that:

- a) The purchaser has not brought the vehicle to any of the inspections and/or to undergo maintenance tasks as required in the user manual, or the date set for these inspections or maintenance tasks has passed. Also excluded from the warranty are defects that appear before the date established for an inspection or



maintenance task that never occurred, or that will occur after the established date.

b) Inspections, maintenance work, or repairs have been conducted by third parties not recognised or authorised by **RIEJU**.

c) Any maintenance or repair has been conducted in violation of the technical requirements, specifications, and instructions set forth by the manufacturer.

d) Replacement parts not authorised for use by **RIEJU** have been used in maintenance or repair work on the vehicle, or if, and to the extent that, fuels, lubricants, or other liquids (including, but not limited to, cleaning products) that were not expressly mentioned in the User Manual's instructions have been used on or in the vehicle.

e) The vehicle has been, in any way, altered or modified or fitted with components other than the components expressly authorised by **RIEJU** as components allowed for the vehicle.

f) The vehicle has been stored or transported in a way that is contrary to technical requirements.

g) The vehicle has been used for a special use other than ordinary use, such as competition, racing, or in an attempt to beat a record.

h) The vehicle has suffered a fall or accident that directly or indirectly causes damages.

## Warranty exclusions

The following articles are excluded from the warranty:

a) Replacements for wear, including, but not limited to, spark plugs, batteries, fuel filters, oil filter elements, chains (secondary), engine output pinions, rear rings, air filters, brake discs, brake pads, clutch disks, bulbs, fuses, carbon brushes, footrest rubber, tyres, chambers, wires, and other rubber components, ex-



haust pipe, and washers.

b) Lubricants (for example, oil, grease, etc.) and operational fluids (for example, battery fluid, coolant, etc.).

c) Inspection, adjustment, and other maintenance work, as well as all kinds of cleaning work.

d) Damage to the paint and consequent rust due to external influences, such as rocks, salt, industrial fumes, and other environmental impacts, or inadequate cleaning with inadequate products.

e) Damages caused by defects, as well as expenses caused directly or indirectly by the defects (for example, communications expenses, lodging expenses, car hire expenses, public transport expenses, recovery vehicle expenses, emergency messenger expenses, etc.) as well as other financial harm (for example, caused by loss of use of a vehicle, lost income, lost time, etc.).

f) Damage caused by overheating to any of the motorcycle's components is not covered by warranty. We recommend strictly following our use and maintenance instructions to avoid this kind of incident.

g) Acoustic or aesthetic circumstances that do not significantly affect conditions for use of the motorcycle (for example, small or hidden imperfections, normal noise or vibration in use, etc.).

h) Circumstances due to vehicle ageing (for example, fading of painted surfaces or metal coating).

### Miscellaneous

a) If repair of the defect or replacing the part is disproportionate, **RIEJU** shall be entitled to decide, at its sole discretion, whether to repair or replace the defective parts. Ownership over the replaced parts, if applicable, shall be held by **RIEJU**, with no other consideration. The dealer authorised by **RIEJU** whom has been entrusted to repair defects shall not be authorised to make binding statements on **RIEJU'S** behalf.



- b) If there is doubt as to whether there is a defect or a visual or material inspection is required, **RIEJU** reserves the right to require that the parts being claimed under the warranty be sent to it, or to request that a **RIEJU** expert examine them. Any additional warranty obligations for replaced parts at no cost or for any services provided at no cost under this warranty shall be excluded. The warranty for replaced components during the warranty period shall end on the expiry date of the warranty period of the respective product.
- c) If a defect cannot be repaired and its replacement is disproportionate for the manufacturer, the consumer under warranty shall be entitled to cancellation of the contract (payment of a compensation) or partial reimbursement of the purchase price (discount) instead of motorcycle repair.
- d) The purchaser's warranty claims under the purchase-sale contract with the authorised dealer shall not be affected by this warranty. This warranty shall not affect the purchaser's additional contractual rights under the general business conditions of the authorised dealer. However, said additional rights may only be claimed with the authorised dealer.
- e) If the purchaser resells the product during the warranty period, the terms and conditions of this warranty shall continue to exist under their current scope, such that rights to claim pursuant to this warranty under the terms and conditions governed by this document shall be transferred to the new owner of the motorcycle.





**RIEJU**

FOR EVERYDAY ADVENTURE